

ERA - G100 / R60

MONTAGEHANDLEIDING - ASSEMBLY MANUAL - MONTAGEANLEITUNG - MANUEL DE MONTAGE

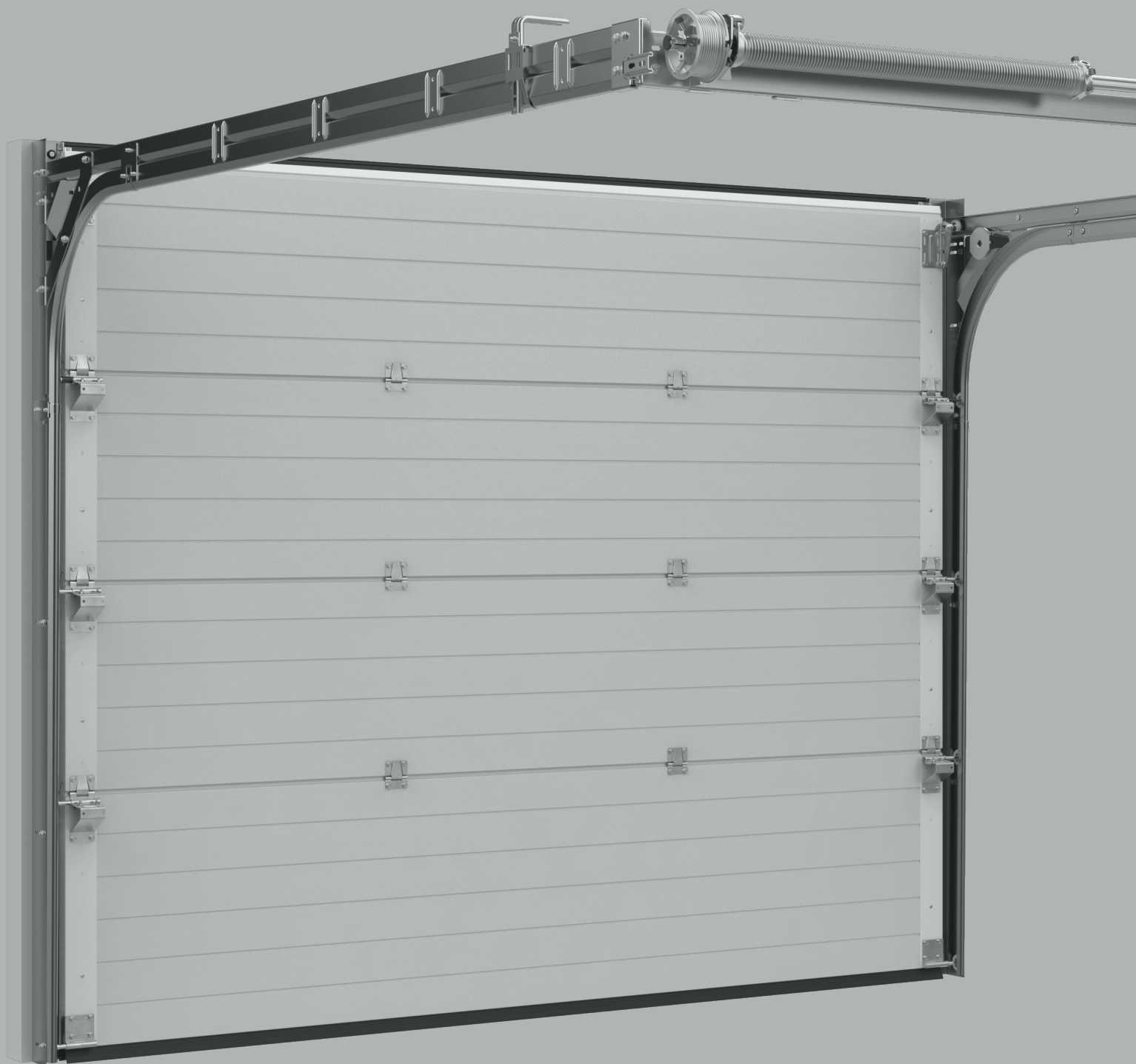

Requirements

NL: Voorschriften
ES: Normativas

FR: Prescriptions
DE: Vorschriften

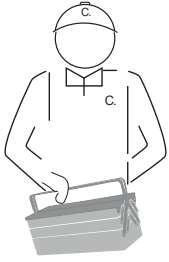

EN: This manual is intended exclusively for competent, qualified personnel.
NL: Deze handleiding is uitsluitend bestemd voor vakbekwame, gekwalificeerde, personen.
FR: Ce manuel est exclusivement destiné à du personnel compétent et qualifié.
ES: Este manual está destinado exclusivamente a personal competente y cualificado.
DE: Diese Anleitung ist ausschließlich für kompetentes, fachkundiges Personal bestimmt.



EN: It is not permitted to use fastening materials that are too small, too light, or not suitable for the intended task.
NL: Het is niet toegestaan bevestigingsmaterialen te gebruiken die te klein, te licht of niet geschikt zijn voor de te volbrengen taak.
FR: Il n'est pas autorisé d'utiliser des éléments de fixation trop petits, trop légers ou non adaptés à la tâche à accomplir.
ES: No está permitido utilizar elementos de fijación que sean demasiado pequeños, demasiado ligeros o no adecuados para la tarea a realizar.
DE: Es ist nicht zulässig, Befestigungsmaterialien zu verwenden, die zu klein, zu leicht oder für die auszuführende Aufgabe nicht geeignet sind.

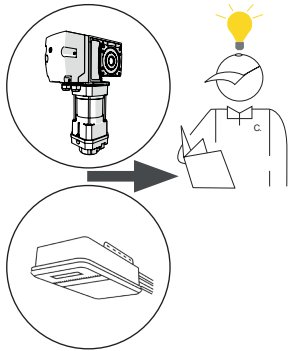

EN: In the case of an electrically operated door, reference is made to the operator manual for installation.
NL: In het geval van een elektrisch aangedreven deur wordt voor de montage verwezen naar de motorhandleiding.
FR: Dans le cas d'une porte à commande électrique, se référer au manuel du moteur pour le montage.
ES: NEn el caso de una puerta accionada eléctricamente, para el montaje se remite al manual del motor..
DE: Bei einer elektrisch betriebenen Tür wird für die Montage auf die Antriebsanleitung verwiesen.

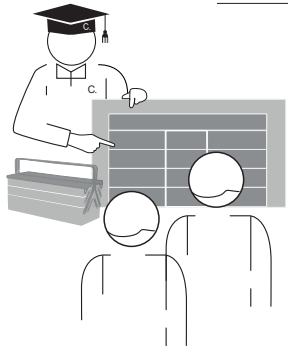

EN: Upon handover of the door, the skilled, qualified and authorised user(s) must be instructed on the safe and correct use of the door.
NL: Bij de oplevering van de deur moet(en) de vakbekwame, gekwalificeerde, bevoegde gebruiker(s) geïnstrueerd worden over het veilige en juiste gebruik van de deur.
FR: Lors de la remise de la porte, le(s) utilisateur(s) compétent(s), qualifié(s) et autorisé(s) doivent être instruits de l'utilisation sûre et correcte de la porte.
ES: En el momento de la entrega de la puerta, los usuarios capacitados, cualificados y autorizados deben ser instruidos sobre el uso seguro y correcto de la puerta.
DE: Bei der Übergabe der Tür müssen die fachkundigen, qualifizierten und befugten Benutzer über die sichere und ordnungs-gemäße Nutzung der Tür unterwiesen werden.

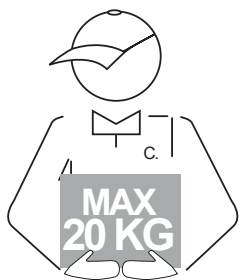

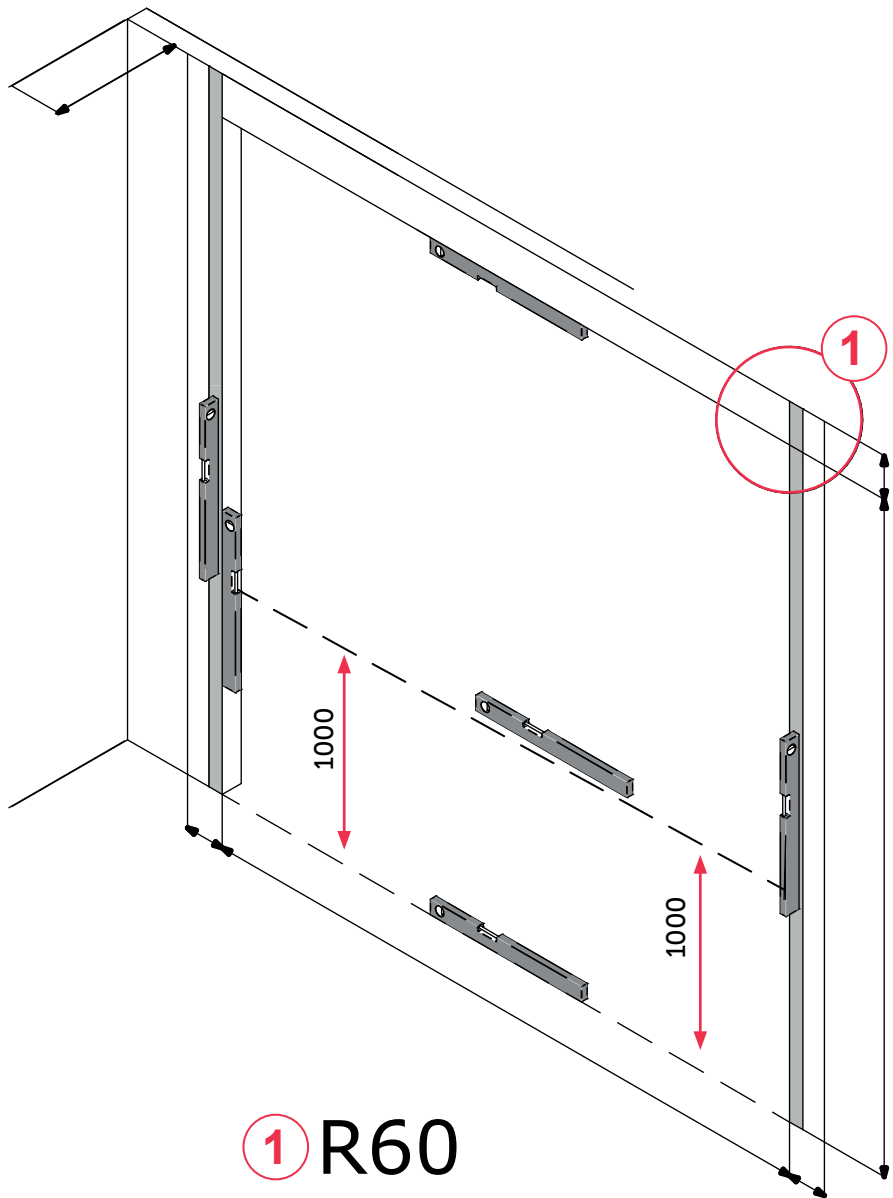
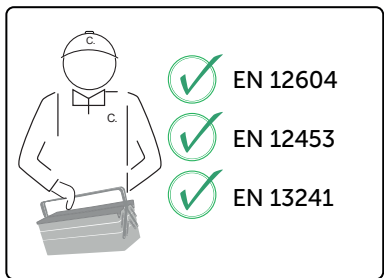
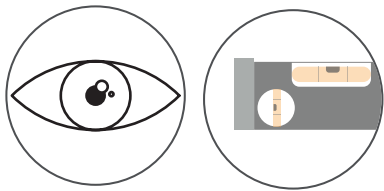

① G100

① R60

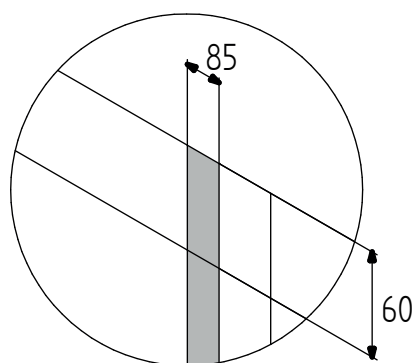
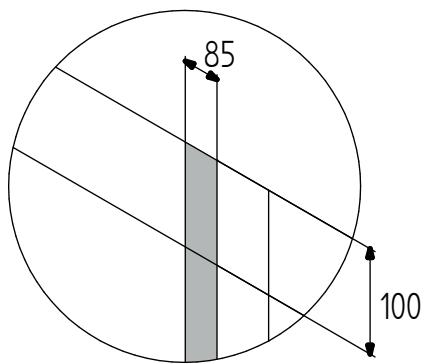

A	B	C	D	E
DLW	DLH	FHR	FSR	FMD
Dagmaat breedte	Dagmaat hoogte	Vrije bovenruimte	Vrije zijruimte	Inbouwdiepte
Day Light Width	Day Light Height	Free Head Room	Free Side Room	Free Mounting Dept
Tageslichtbreite	Tageslichthöhe	Sturzfreiraum	Freie Seitenraum	Freie Einbautiefe
Largeur de bai	Hauteur de baie	Linteau disponible	Ecoinçons Recuiss	Recul
Lățime Gol	Înălțime Gol	Buiandrug Liber	Spațiul Liber Lateral	Spațiul Liber în Adâncime
Szélesség	Magasság	Szabad szemöldök magasság	Szabad hely oldalt	Szabad beépítési mélység

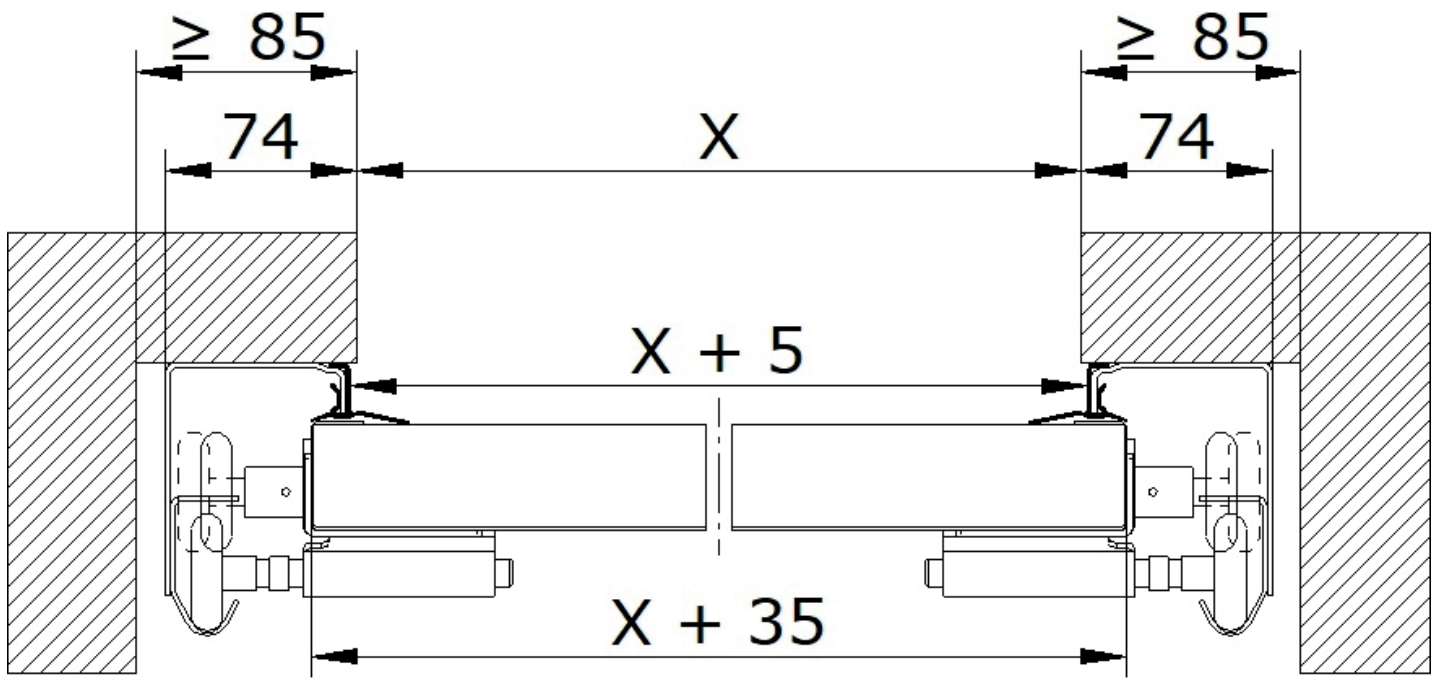

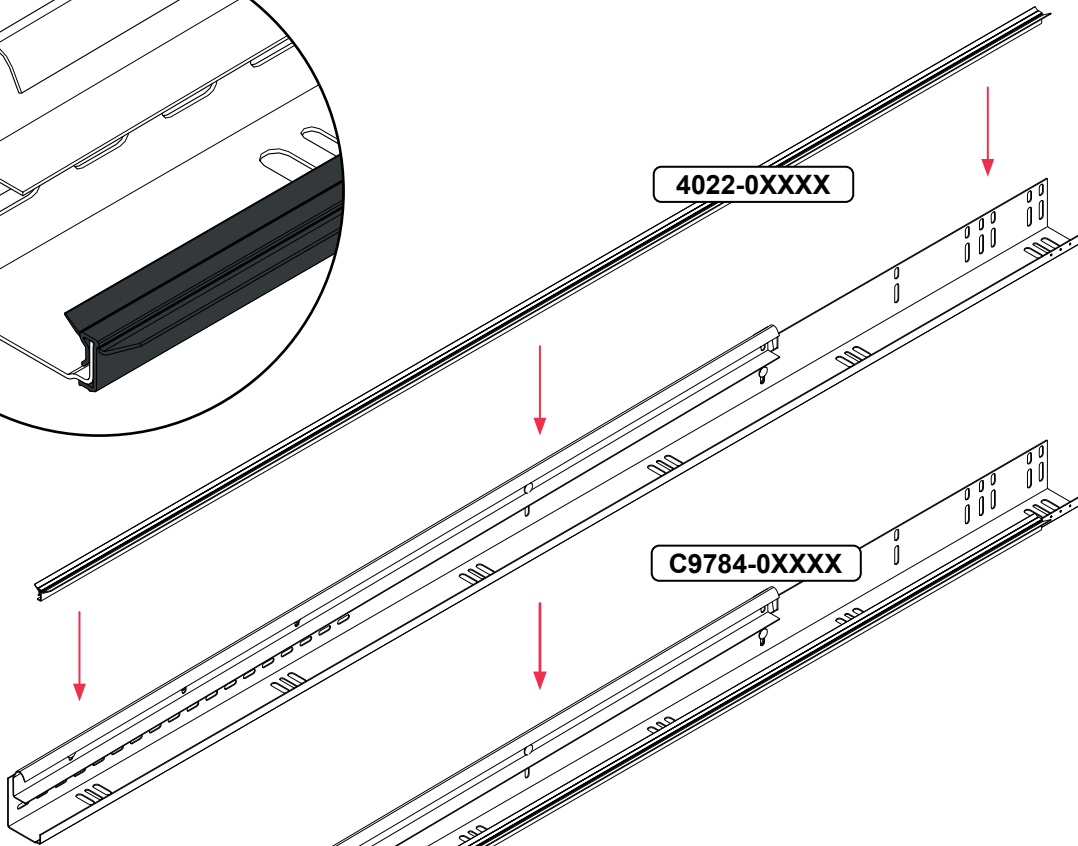
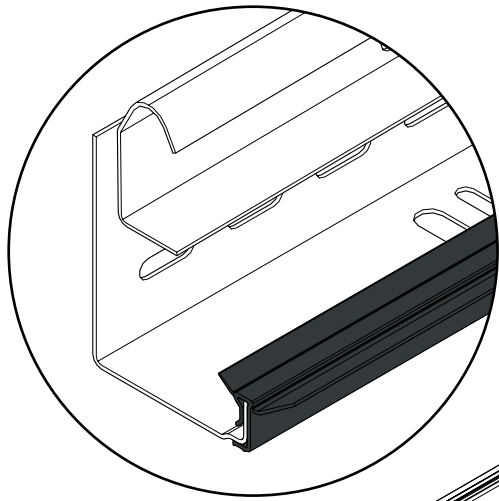

4022-0XXXX

C9784-0XXXX

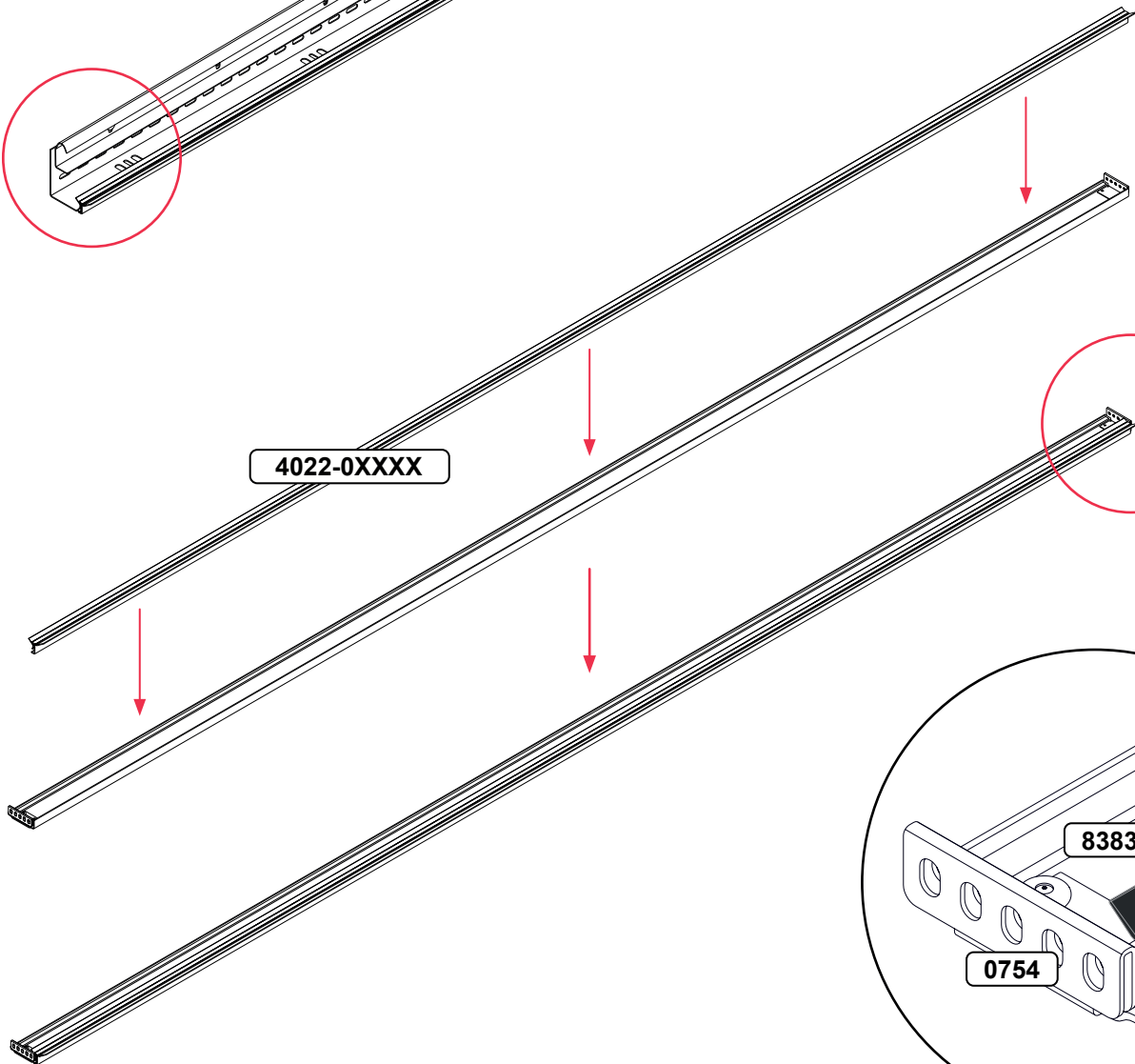

4022-0XXXX

4022-0XXXX

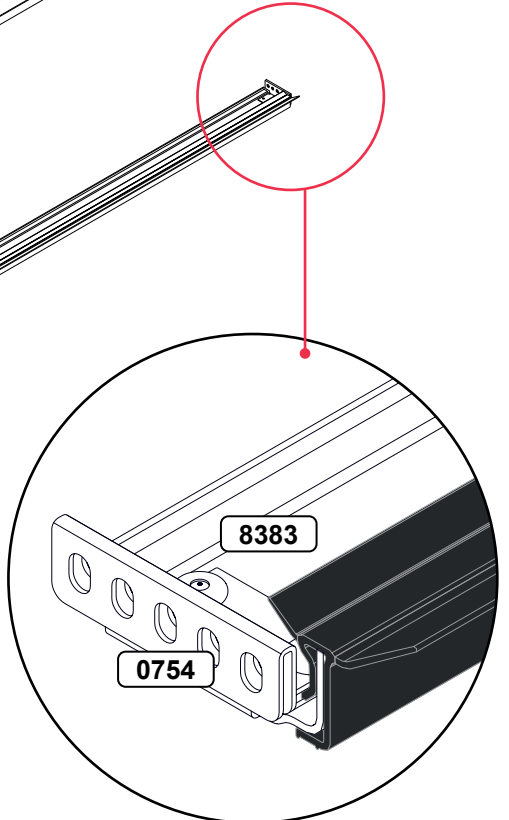

8383

0754

L + R

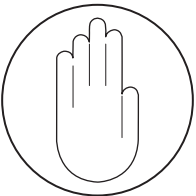
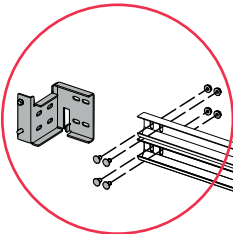

C9783-0XXXX
C9520-0XXXX
C9521-0XXXX

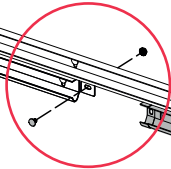

3998/ 3999

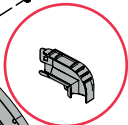

3949

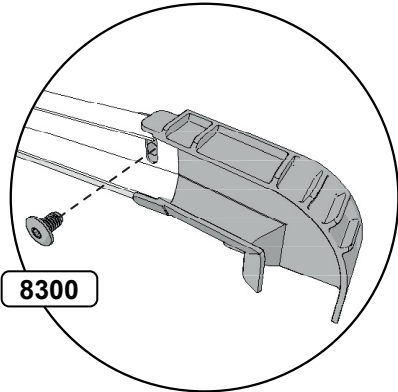
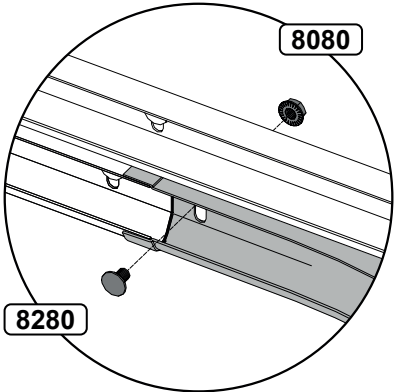
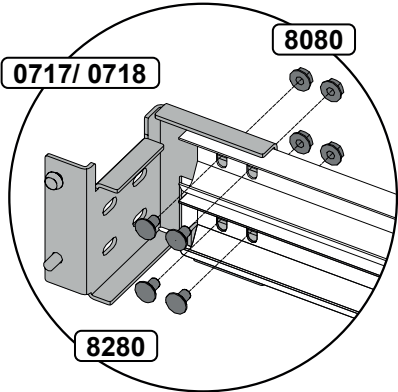

L + R

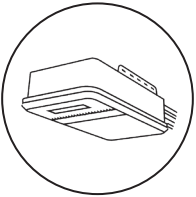
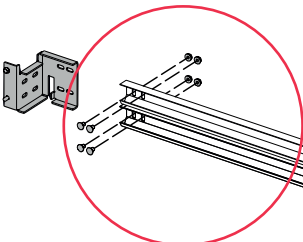

C9830-0XXXX
C9510-0XXXX
C9511-0XXXX

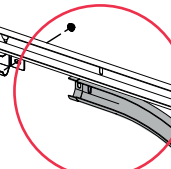

3949

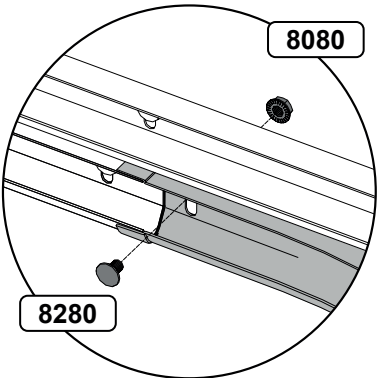
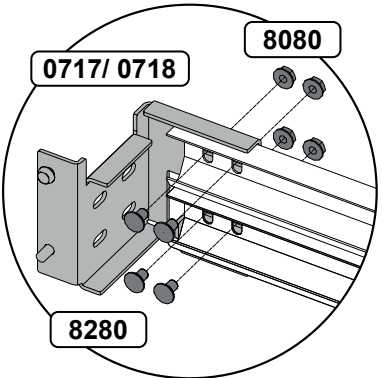

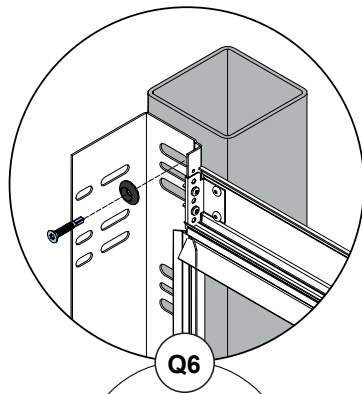

Q6

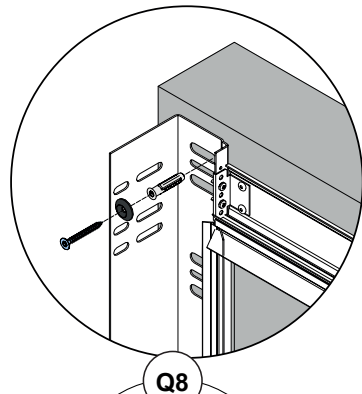

Q8

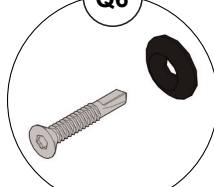

C9958

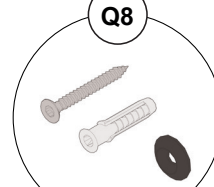

C9959

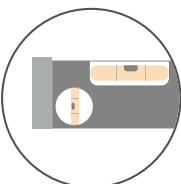
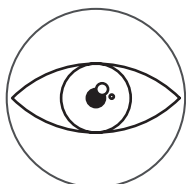
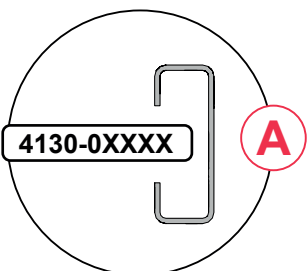
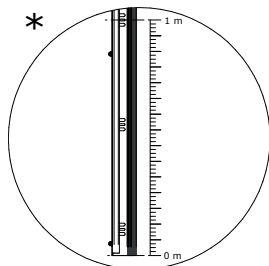
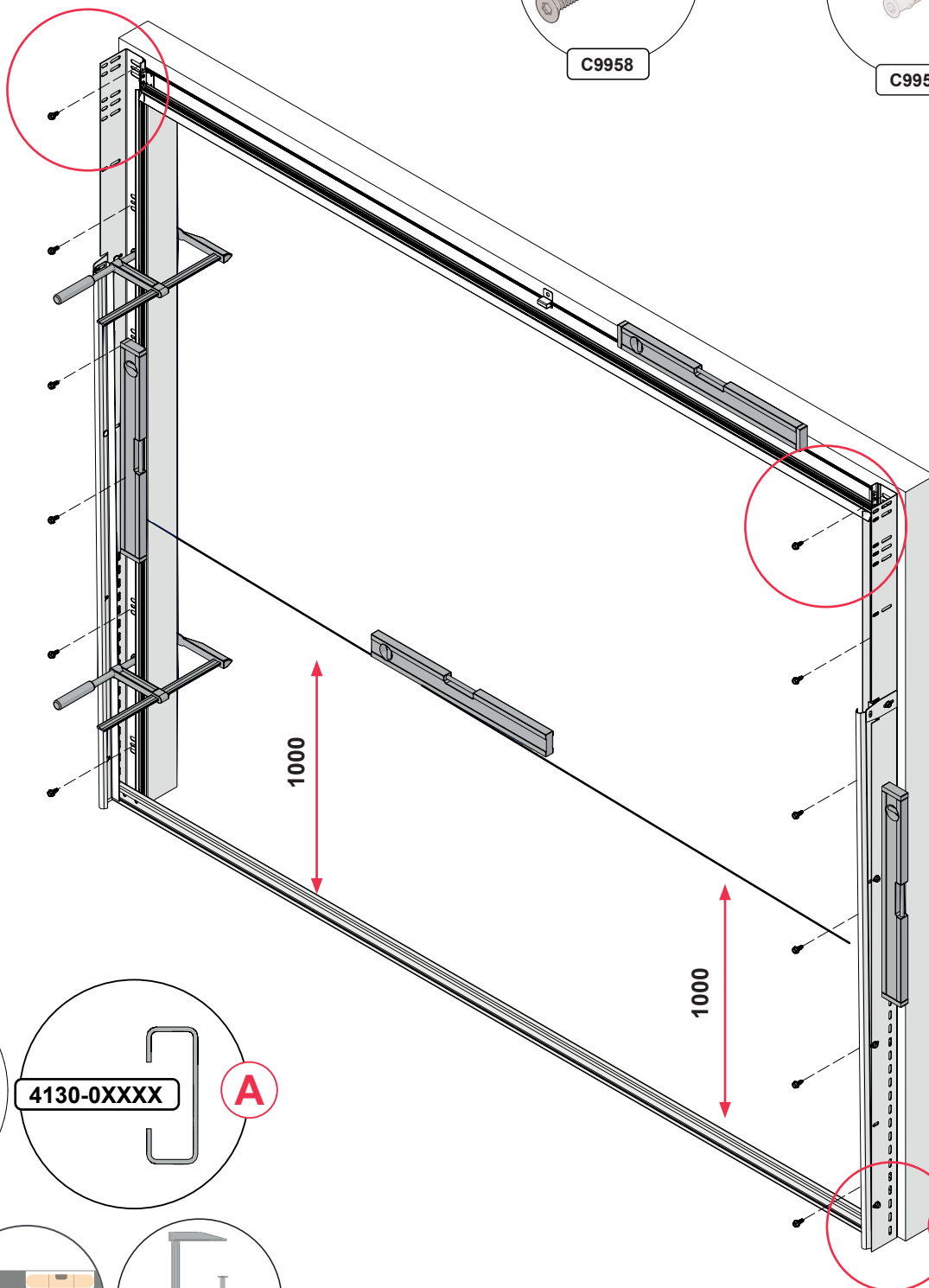

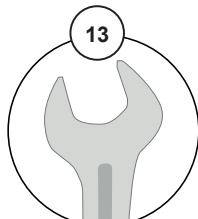
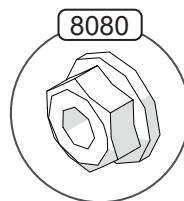
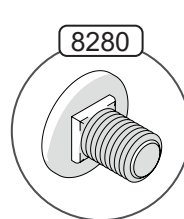
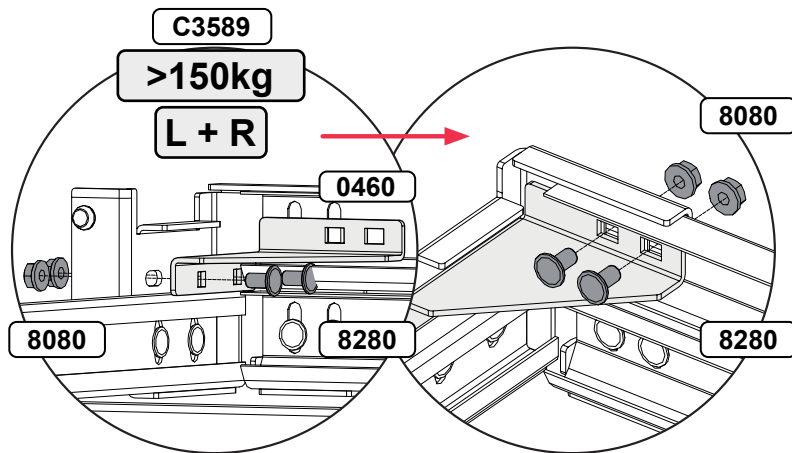
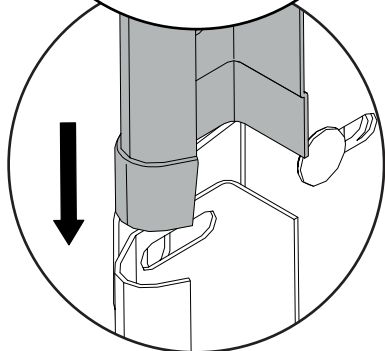
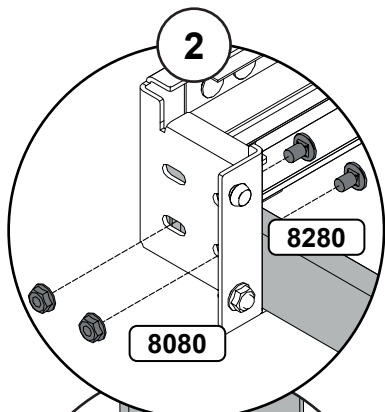
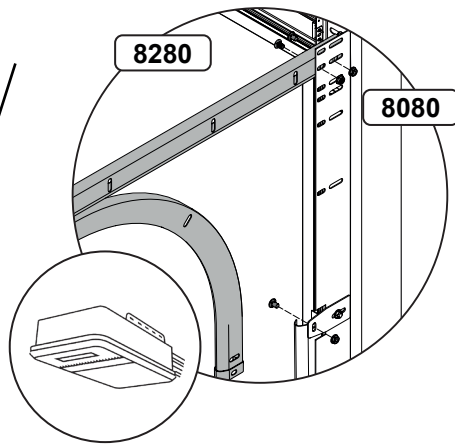
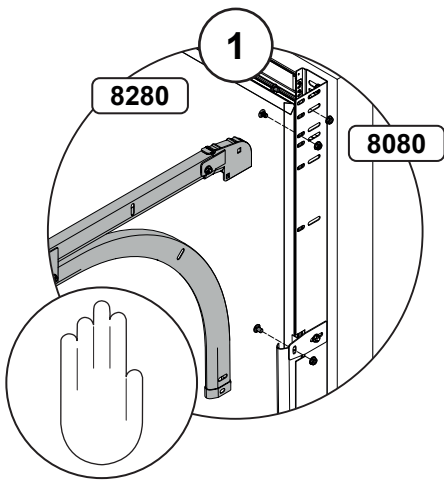
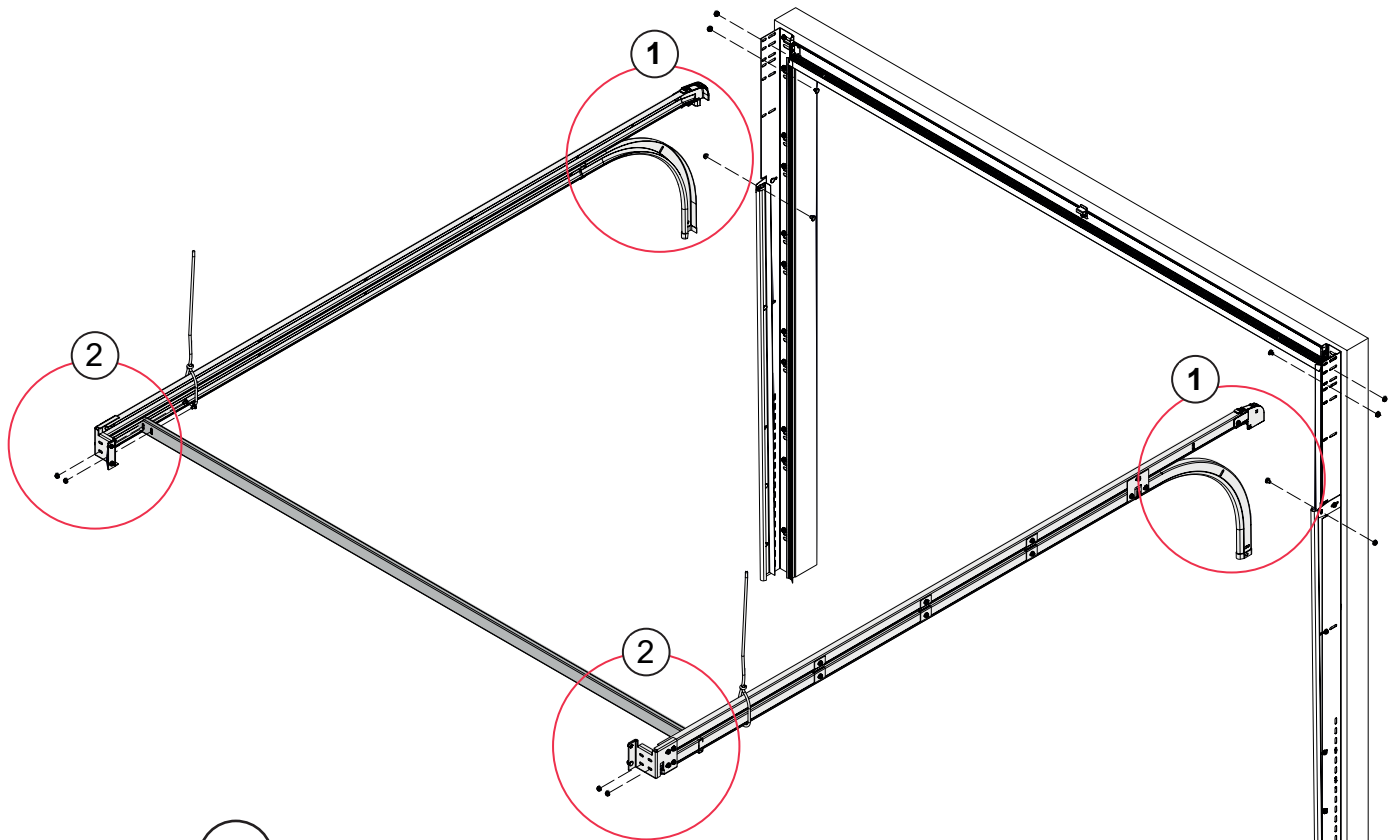

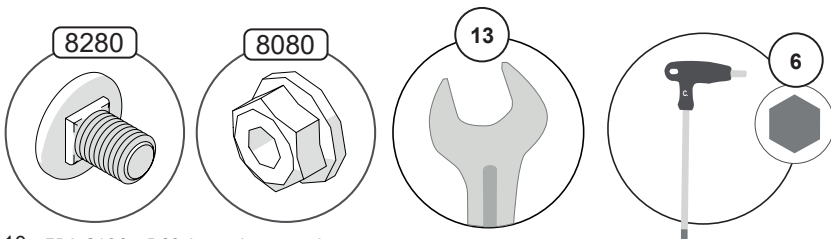
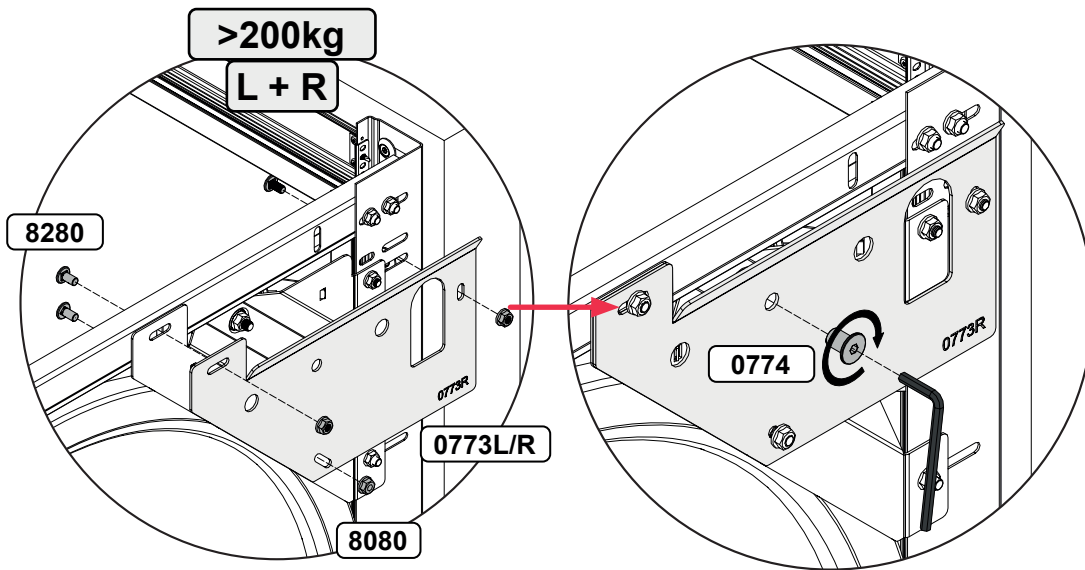
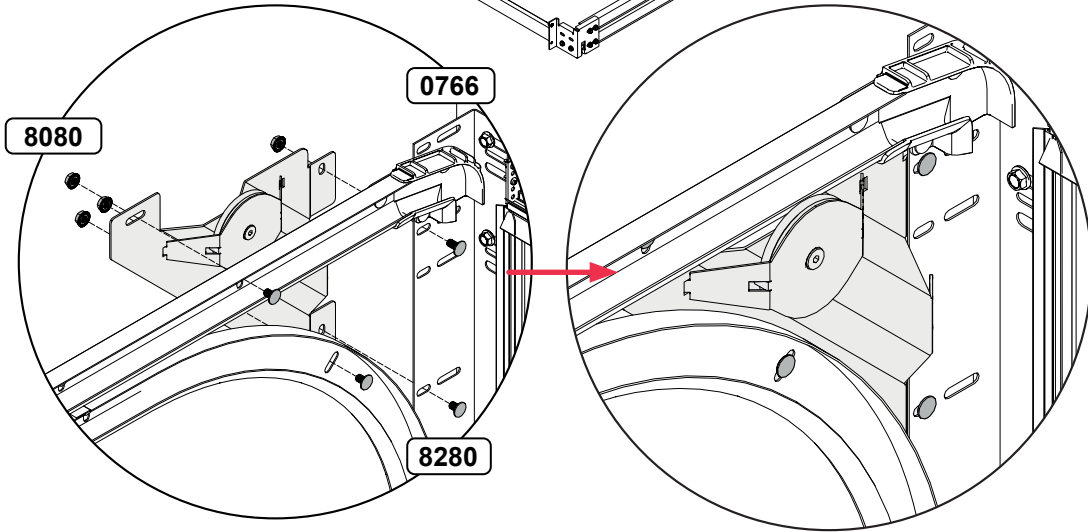
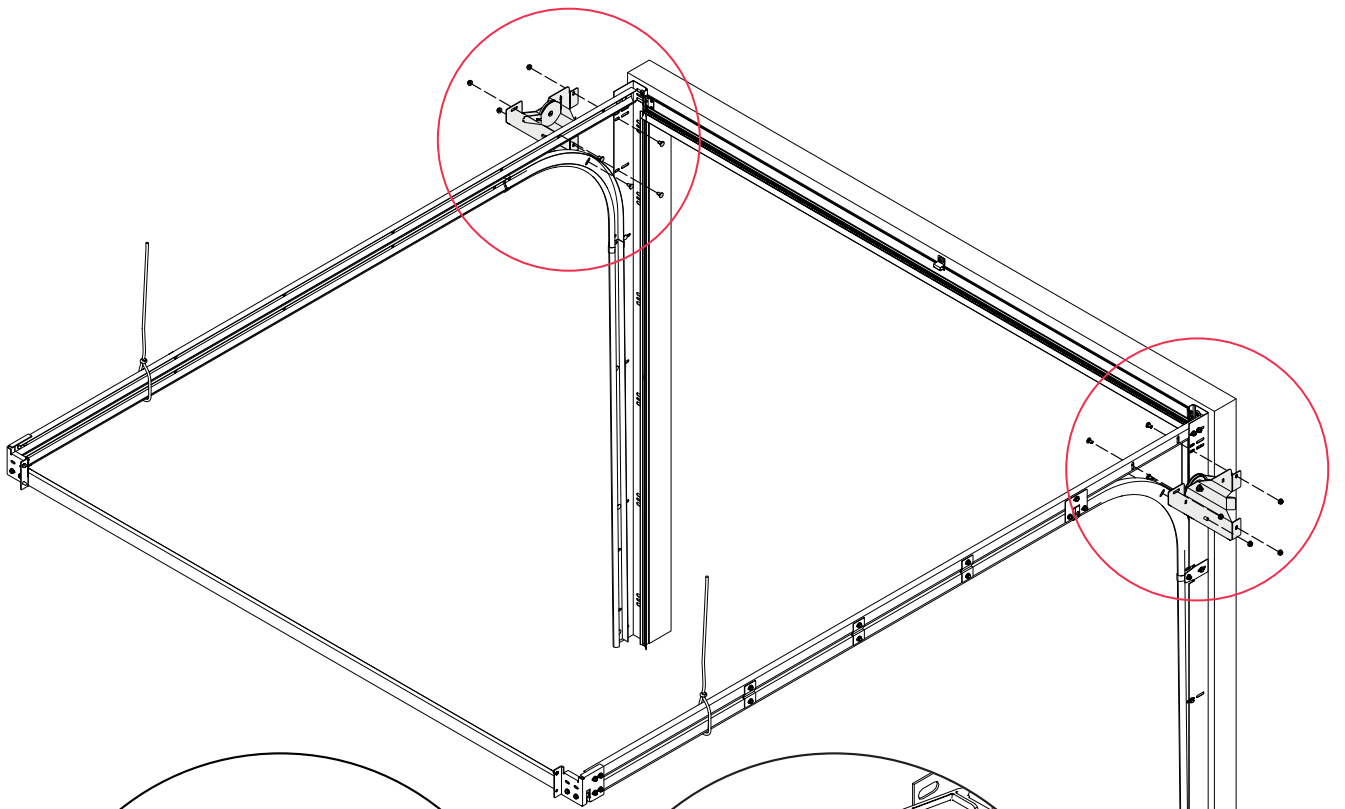

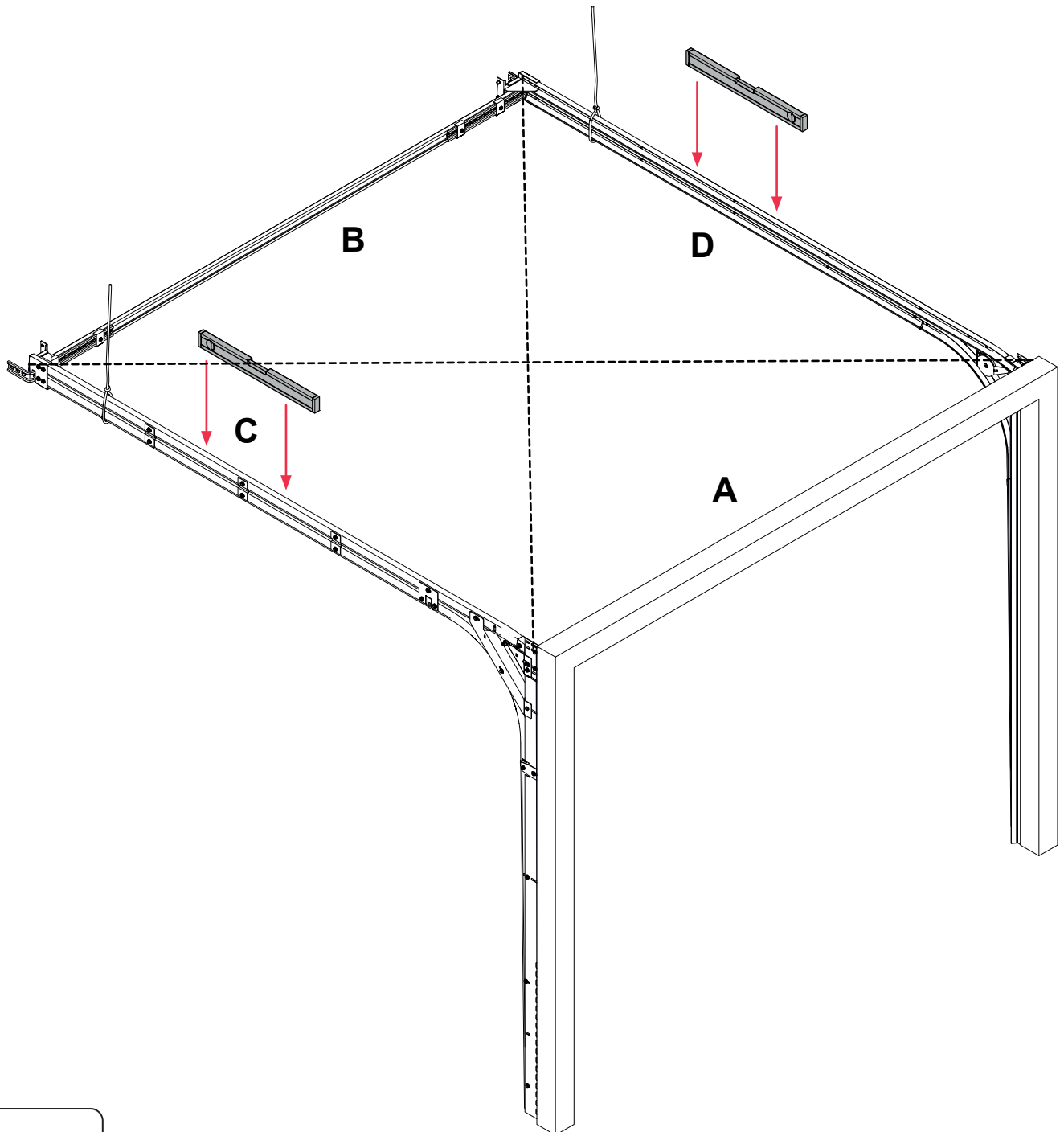

A=B
C=D

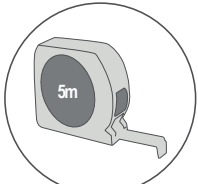
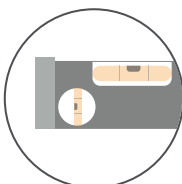
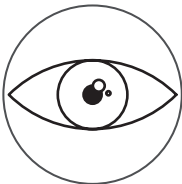

NL: **94044** Beugel afhangprofiel 107x66 mm
 EN: **94044** Mounting plate for fixing angle 107x66 mm hole M8
 FR: **94044** Equerre de montage pour susp.rails 107x66 mm M8
 ES: **94044** Soporte perfil de suspensión 107x66 mm
 DU: **94044** Abhäng Winkel Garagentorschiene 107x66 mm Loch M8

1

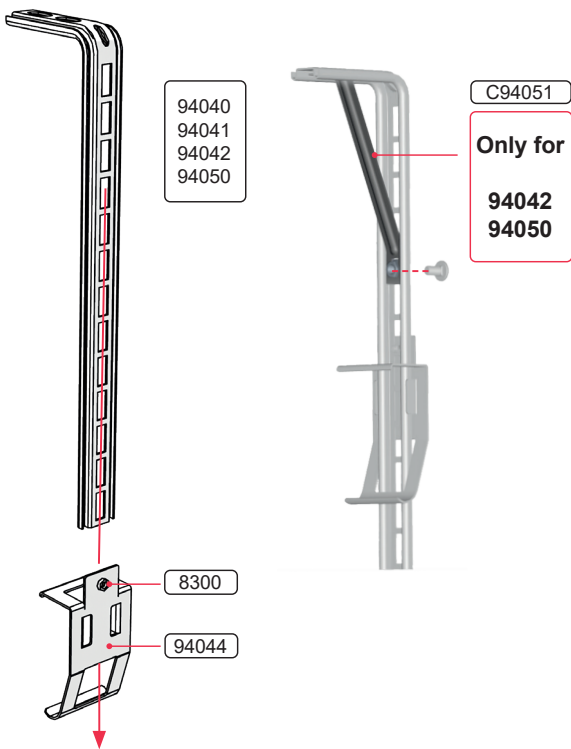

2

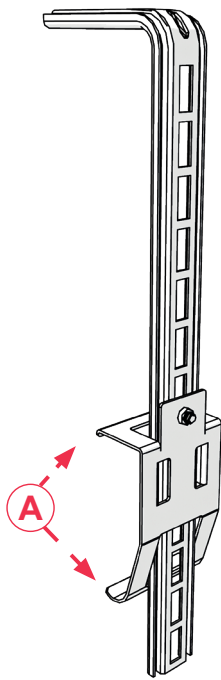

3

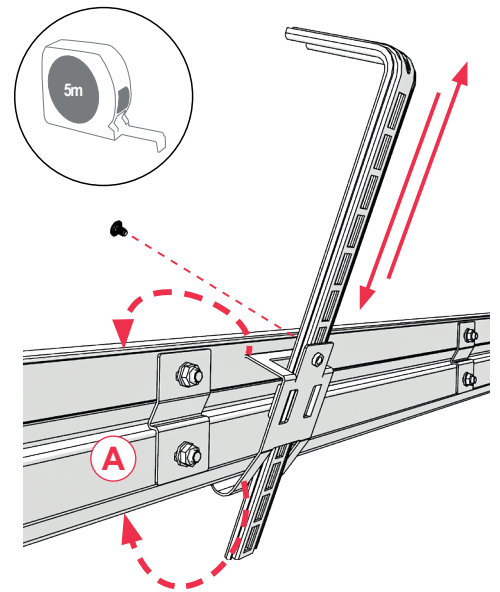

4

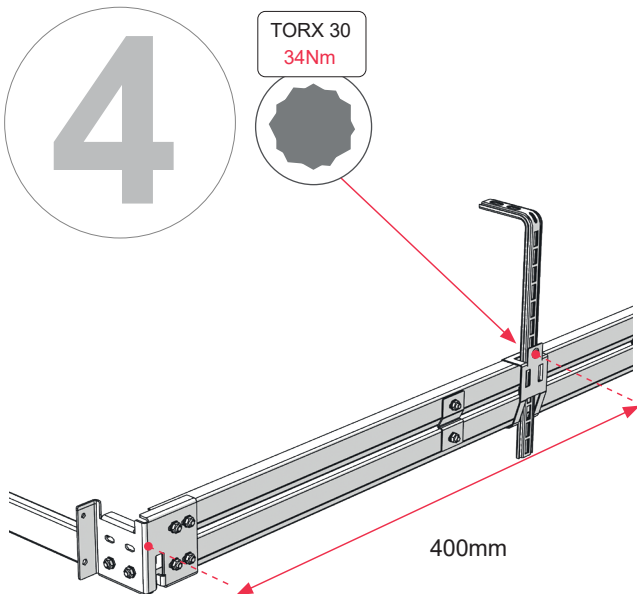

5

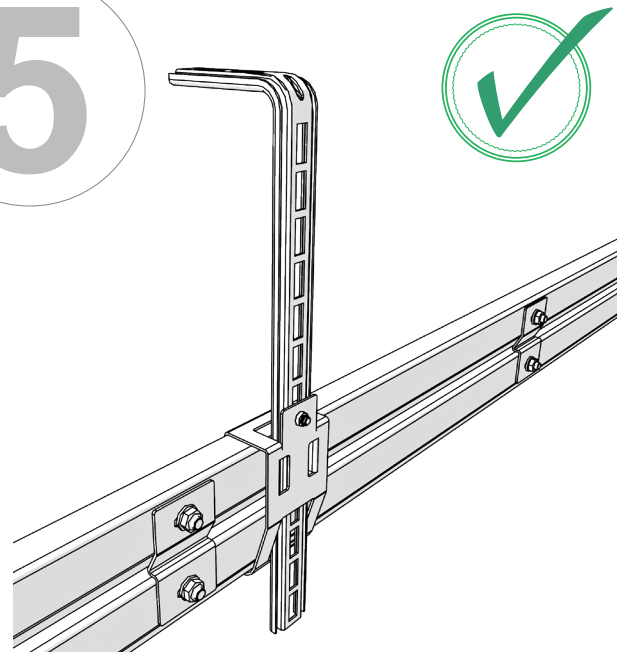

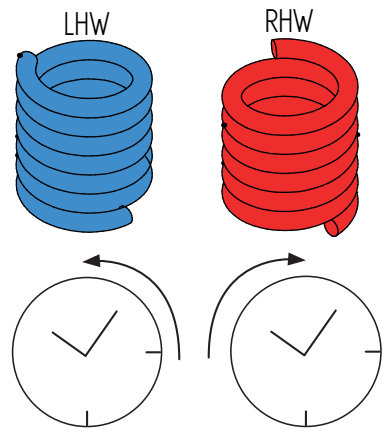
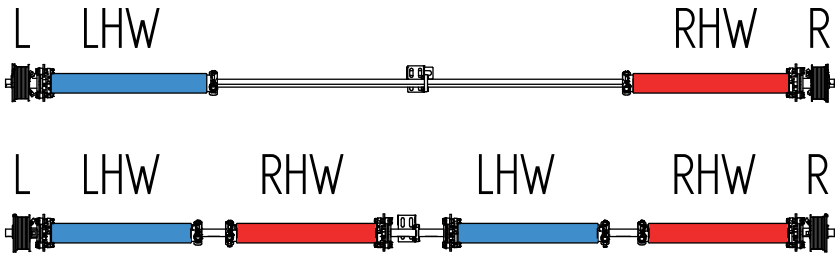

DLH
 0-2489 = 3126
 ≥2490 = 3101

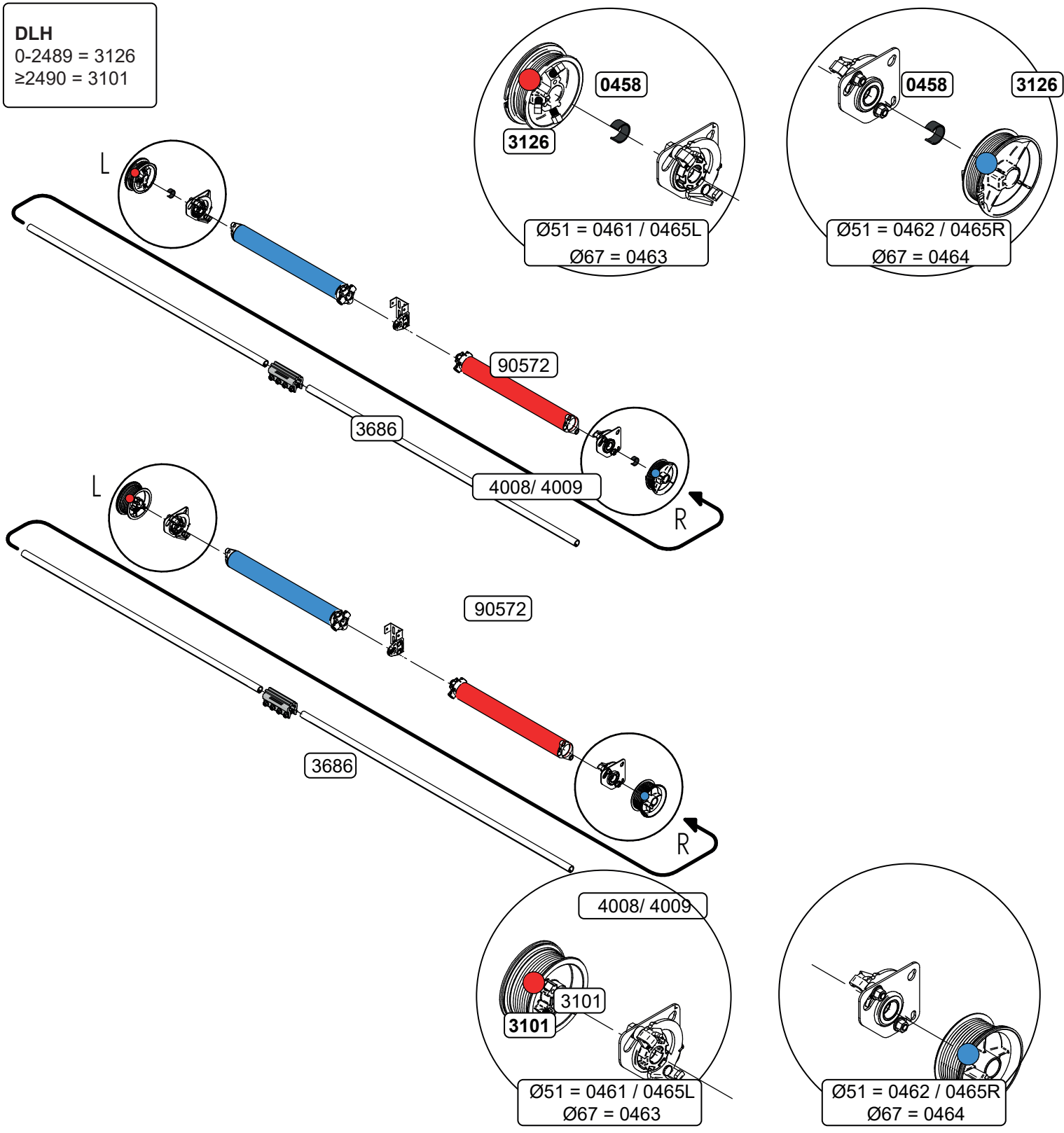

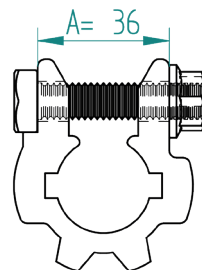
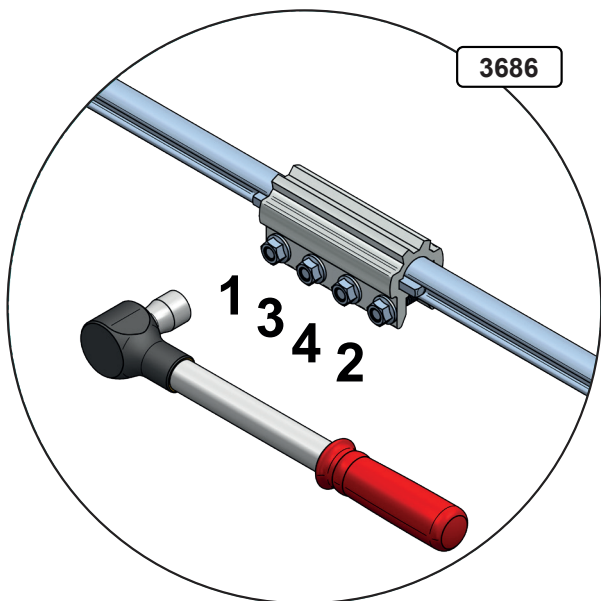

NIET AANGETROKKEN

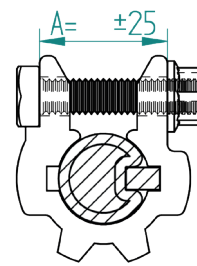

AANGETROKKEN

NL: NIET AANGETROKKEN
 EN: NOT ATTRACTED
 FR: PAS ATTIRÉ
 ES: NO APRETADO
 DE: NICHT ANGEZOGEN

NL: AANGETROKKEN
 EN: ATTRACTED
 FR: ATTIRÉ
 ES: APRETADO
 DE: ANGEZOGEN

1. Eerste de bouten aandraaien in deze volgorde:
 1-3-4-2 Bouten aandraaien met **(+/- 20Nm)**

2. Eerste de bouten aandraaien in deze volgorde:
 1-3-4-2 Bouten aandraaien met **(+/- 27Nm)**

1. First tighten the bolts in the following order:
 1-3-4-2 Tighten the bolts to approx. **(+/- 20Nm)**

2. First tighten the bolts in the following order:
 1-3-4-2 Tighten the bolts to approx. **(+/- 27Nm).**

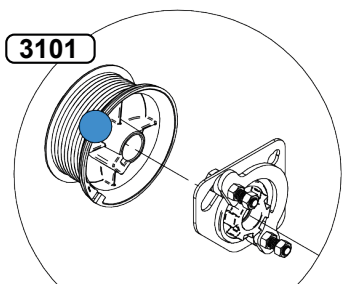

Ø51 = 0461 / 0465L
 Ø67 = 0463

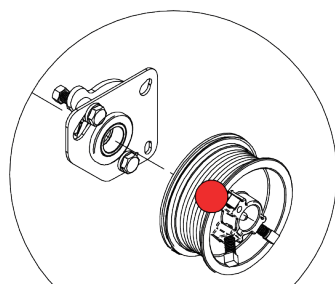

Ø51 = 0462 / 0465R
 Ø67 = 0464

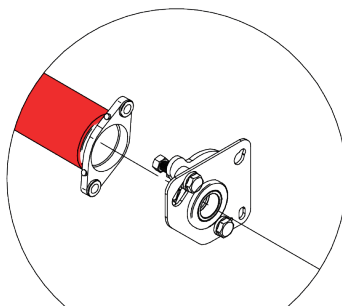

Ø51 = 0462 / 0465R
 Ø67 = 0464

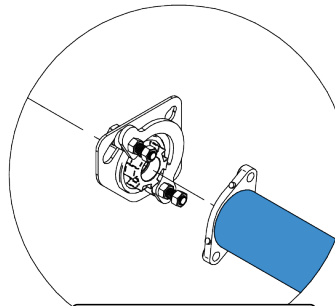

Ø51 = 0461 / 0465L
 Ø67 = 0463

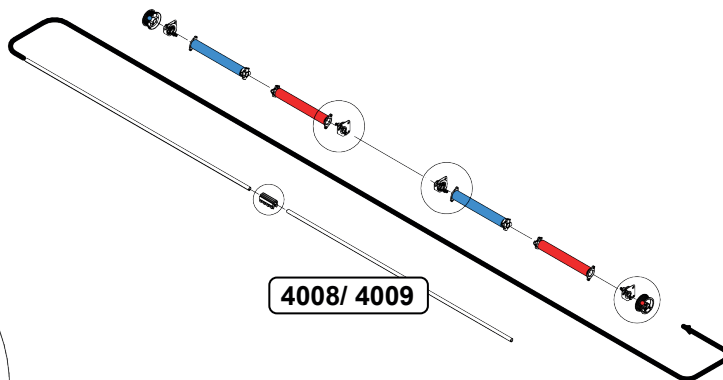

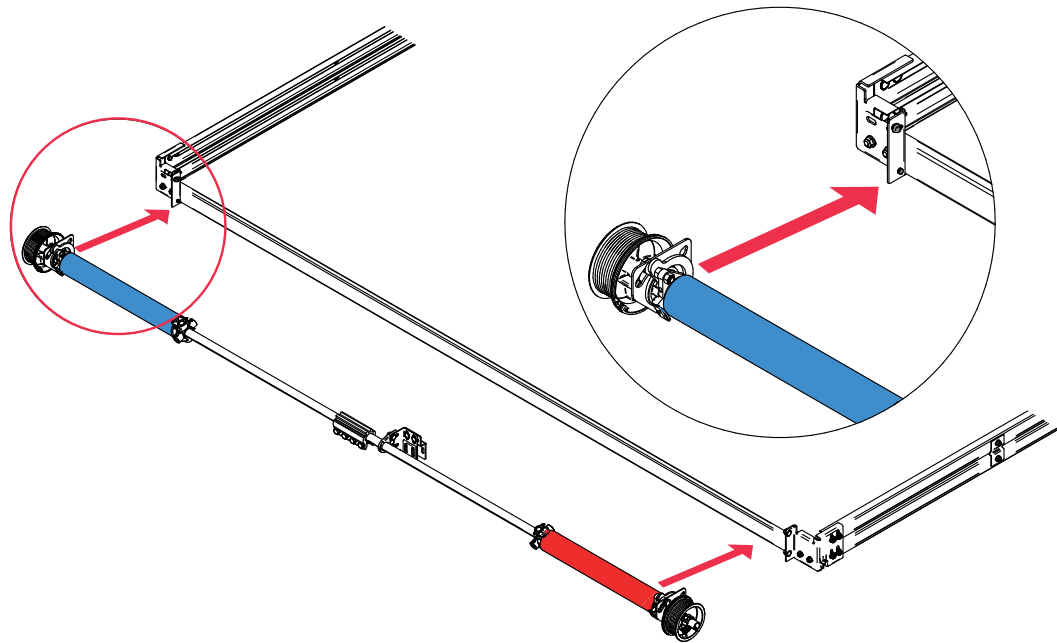
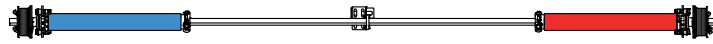

Ø51 = 0461 / 0462 / 0465
Ø67 = 0463 / 0464

0717 +
0718

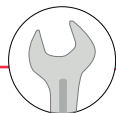
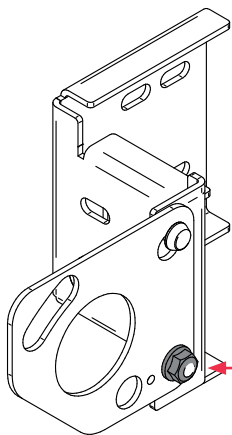
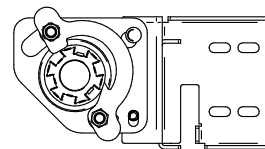
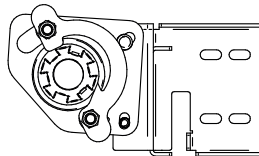
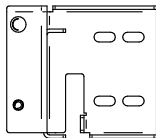
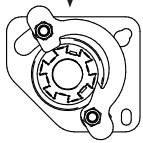

8080

0753

8280

90572

3764

13

8280

8080

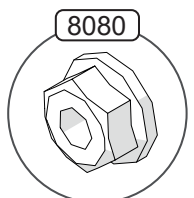
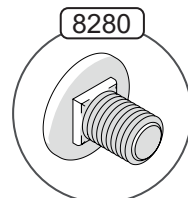
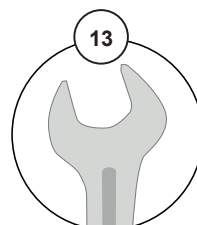

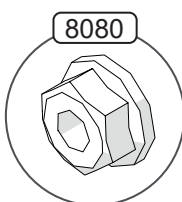
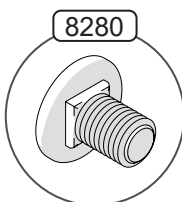
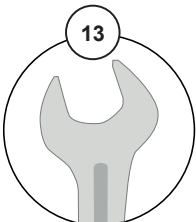
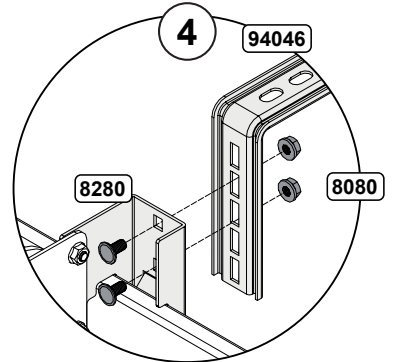
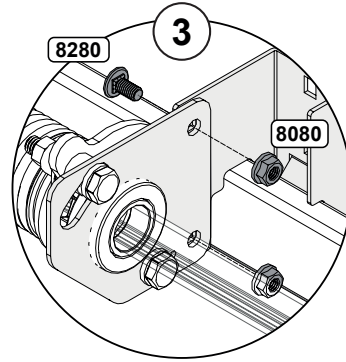
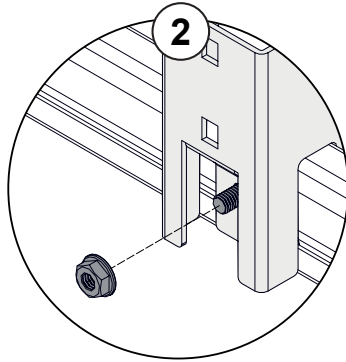
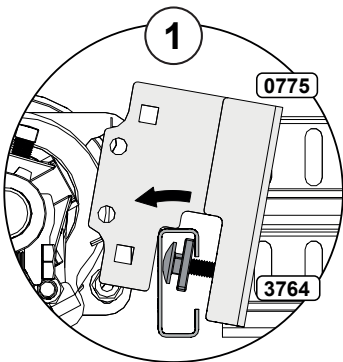
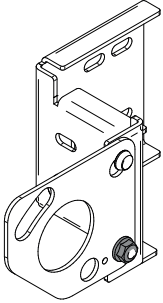
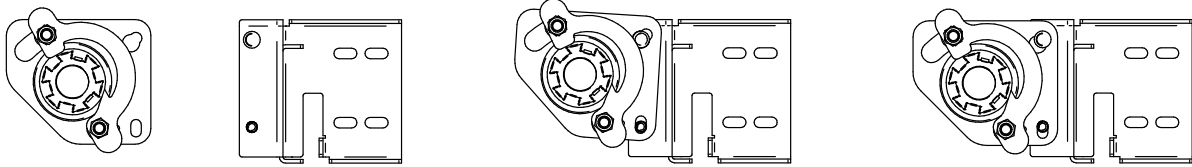
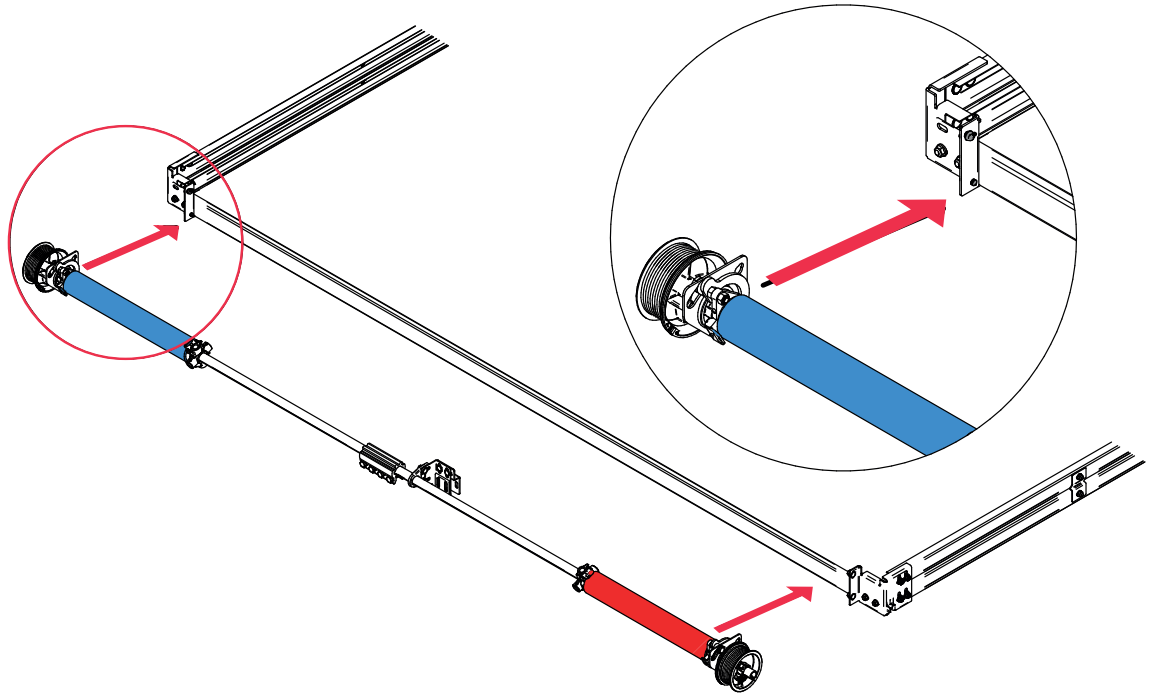
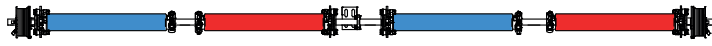

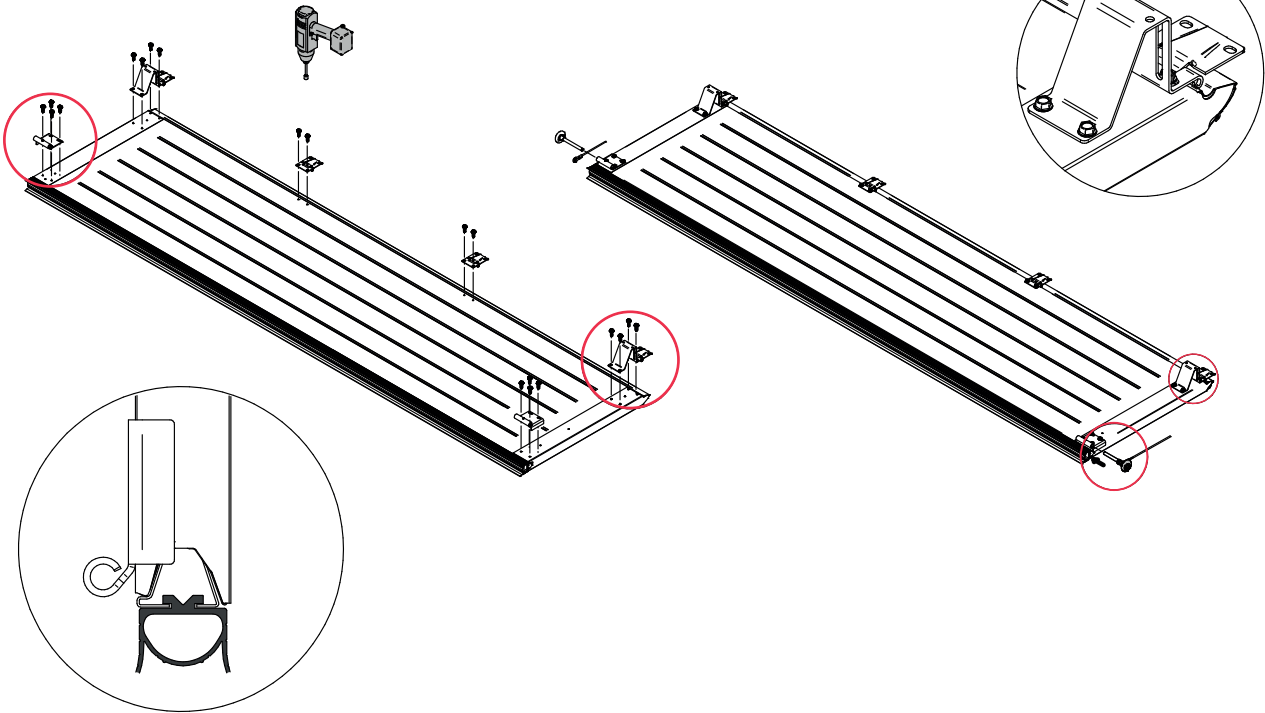
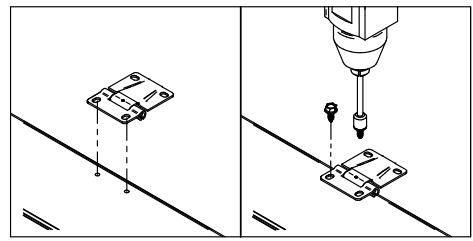
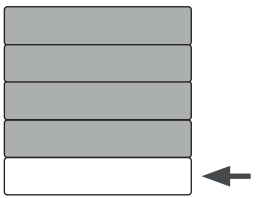

3645

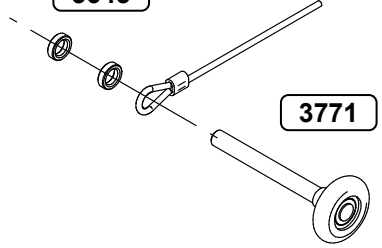

3771

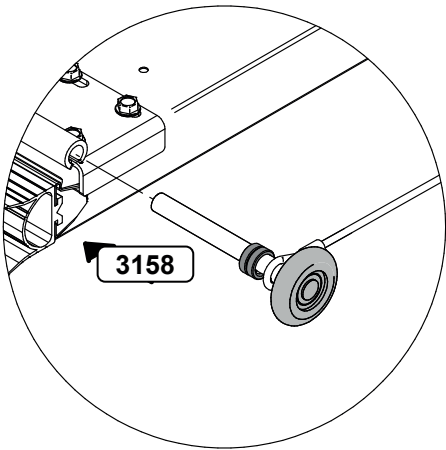

3158

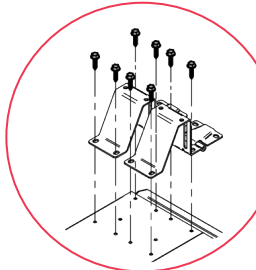
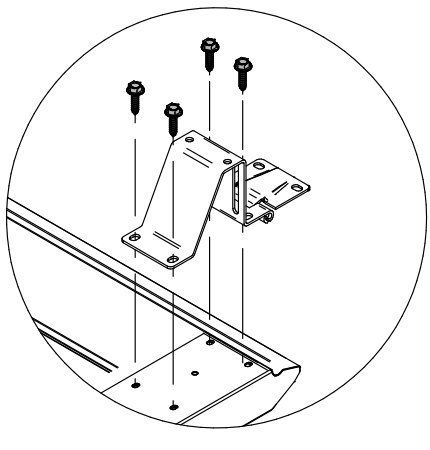
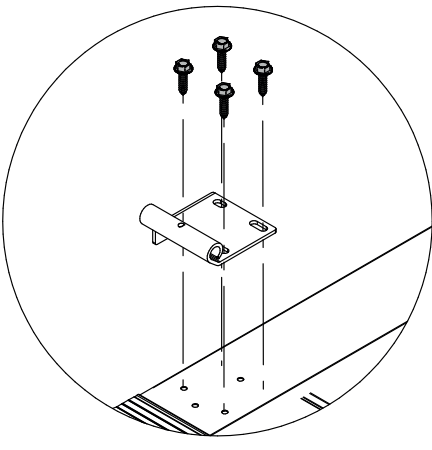

DLW >= 5000mm

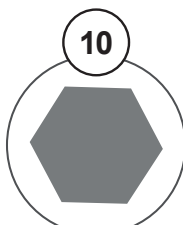
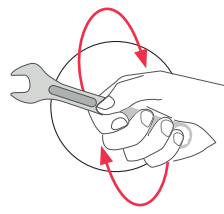

3814 (16mm)
3812 (25mm)

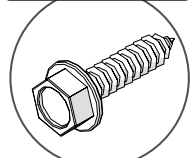

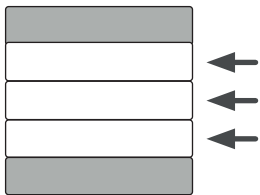

ST

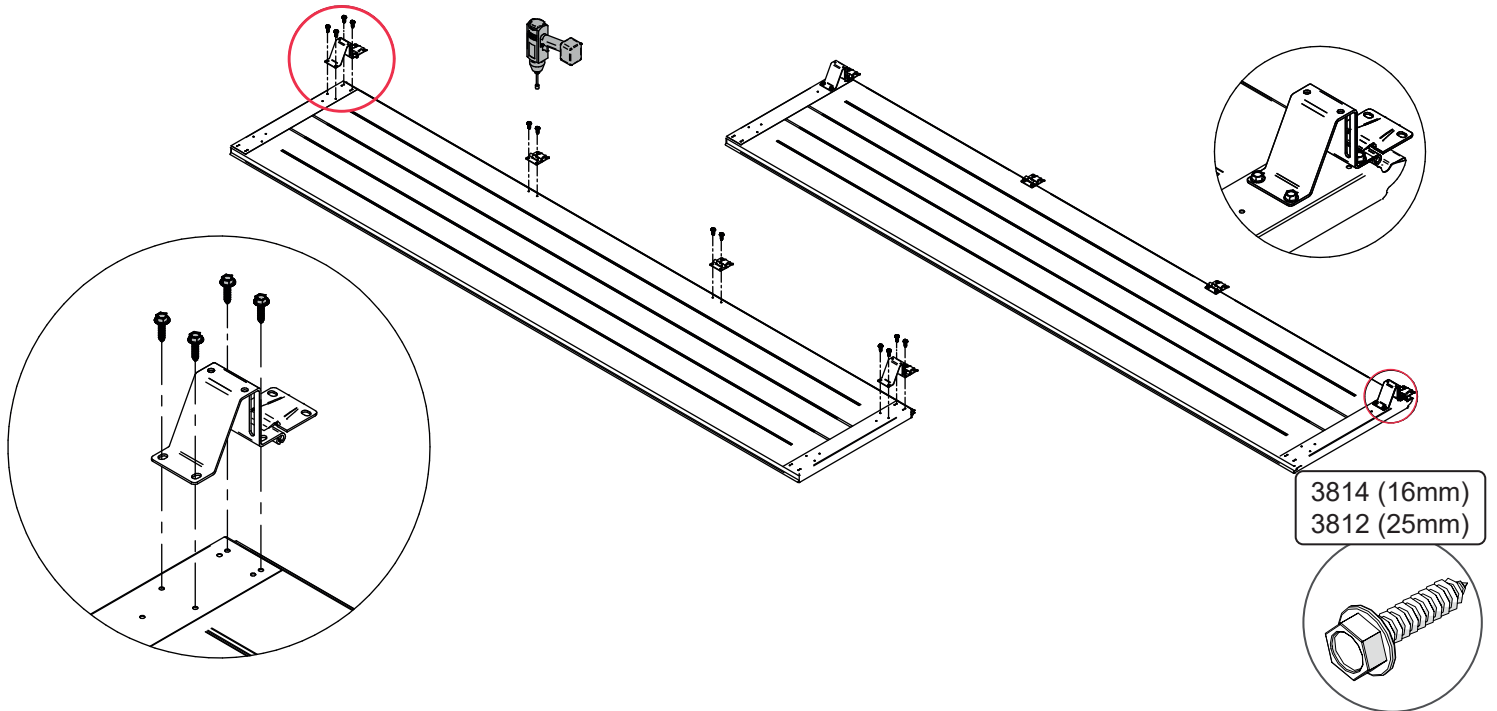
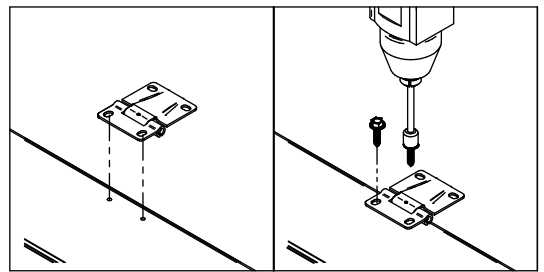

3814 (16mm)
3812 (25mm)

AR

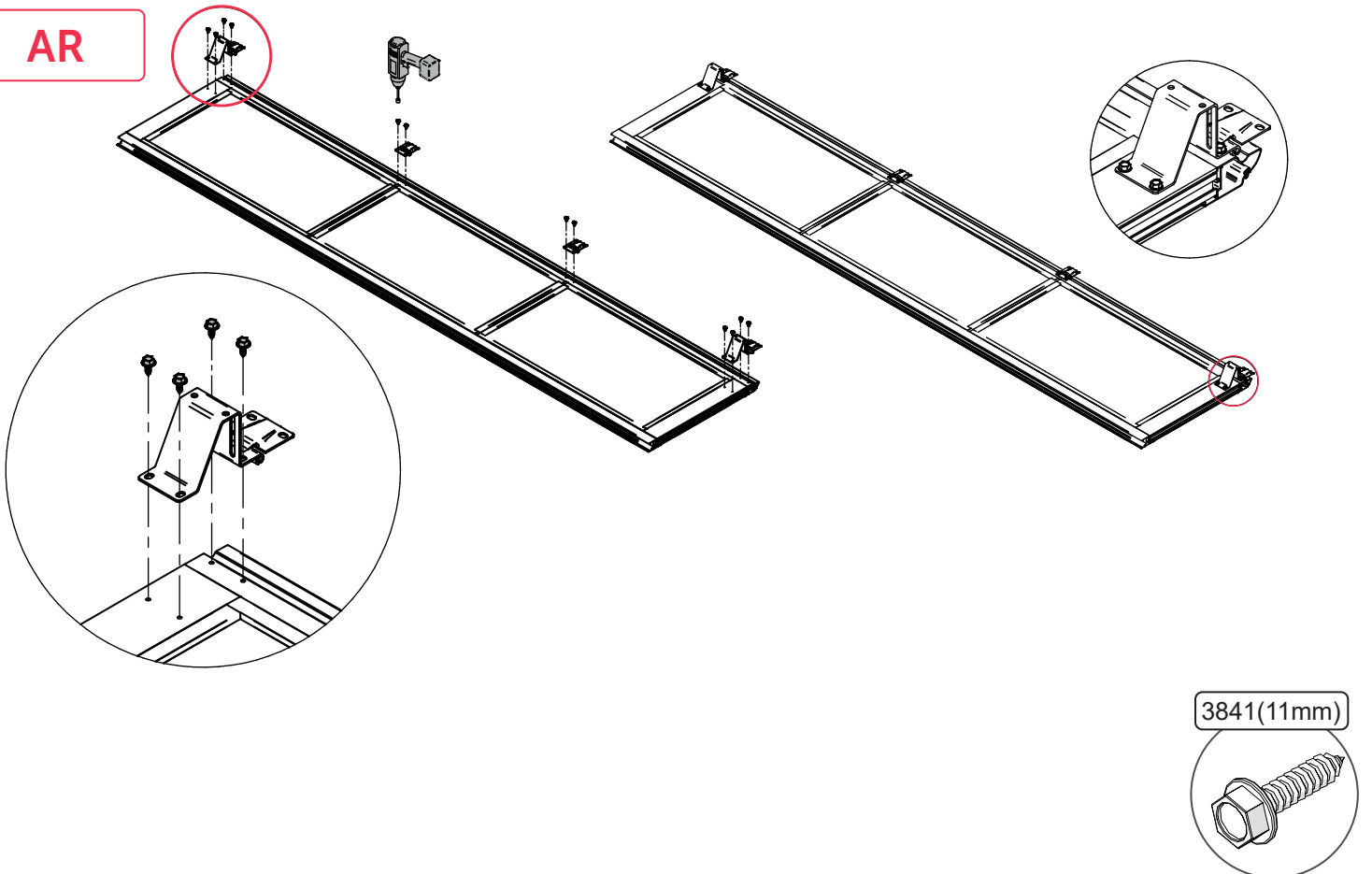

3841(11mm)

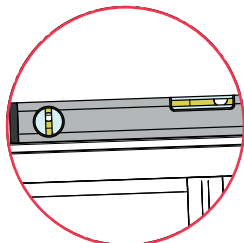
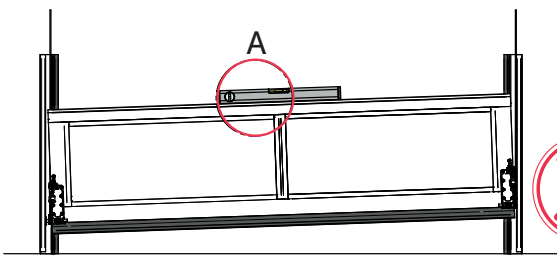
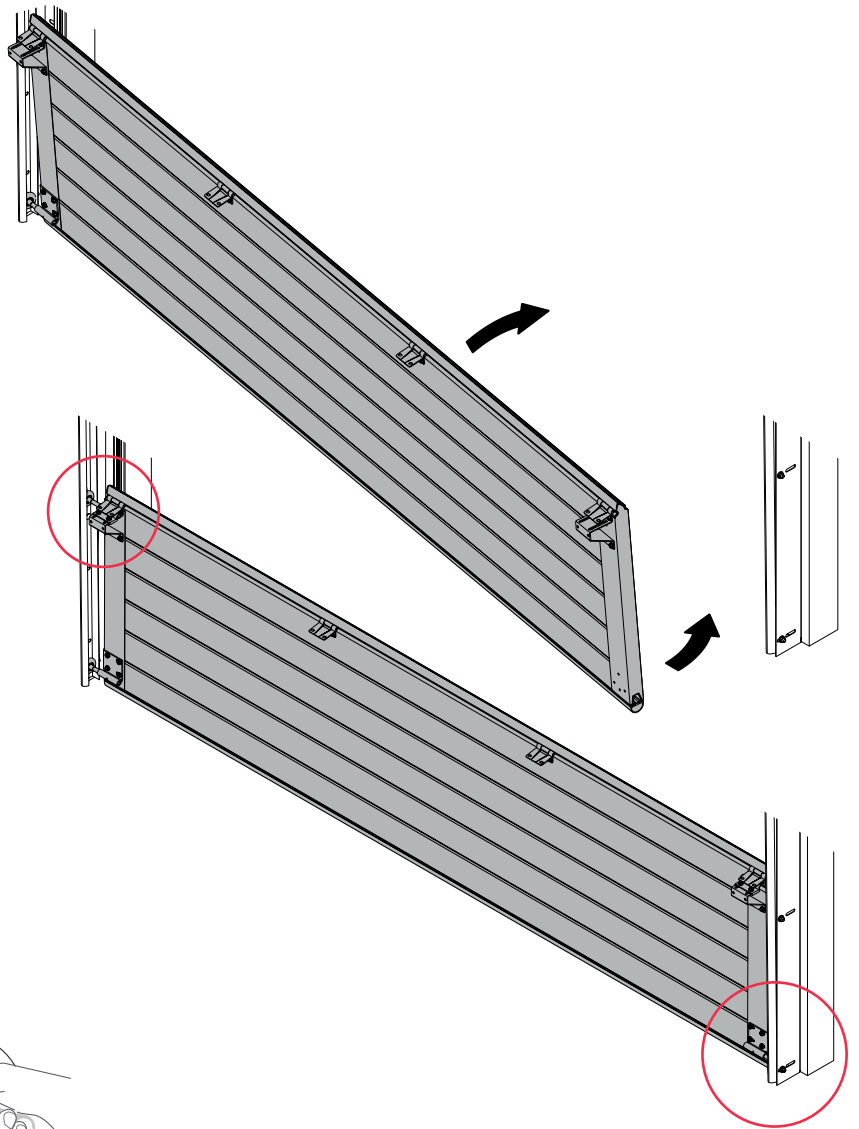
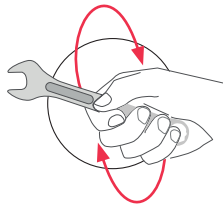
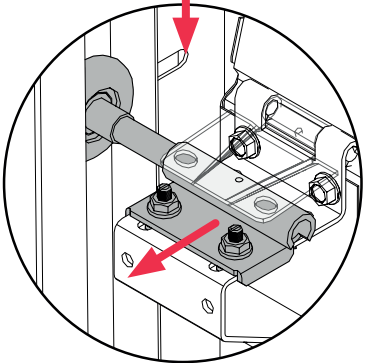
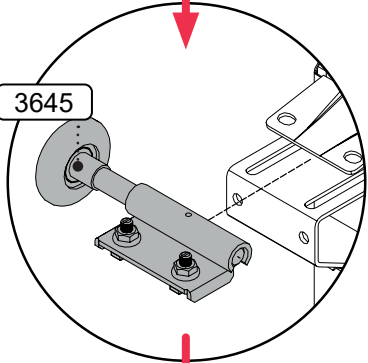
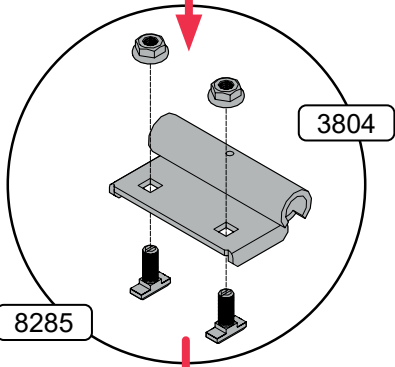
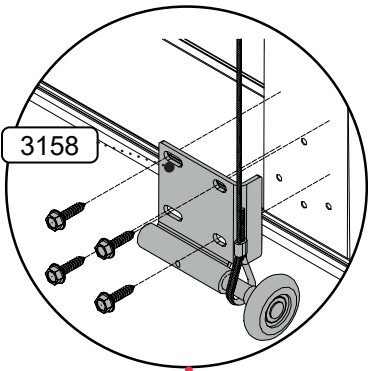

DETAIL A

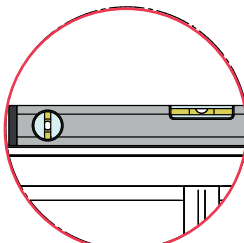
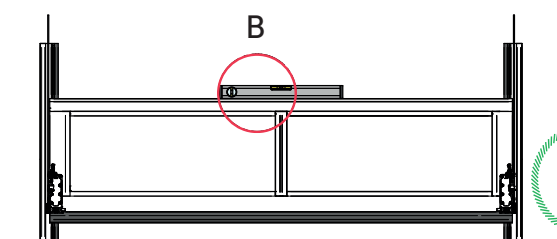
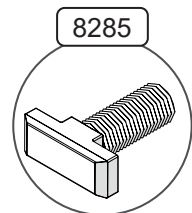
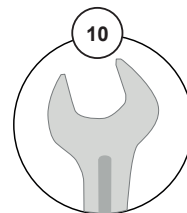

DETAIL B

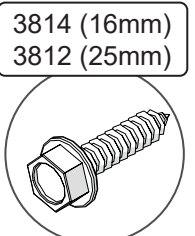
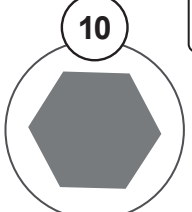
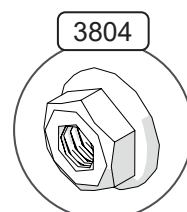

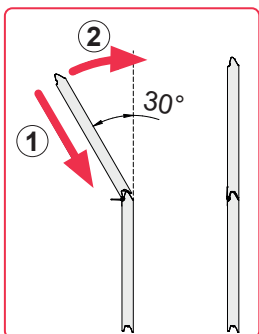
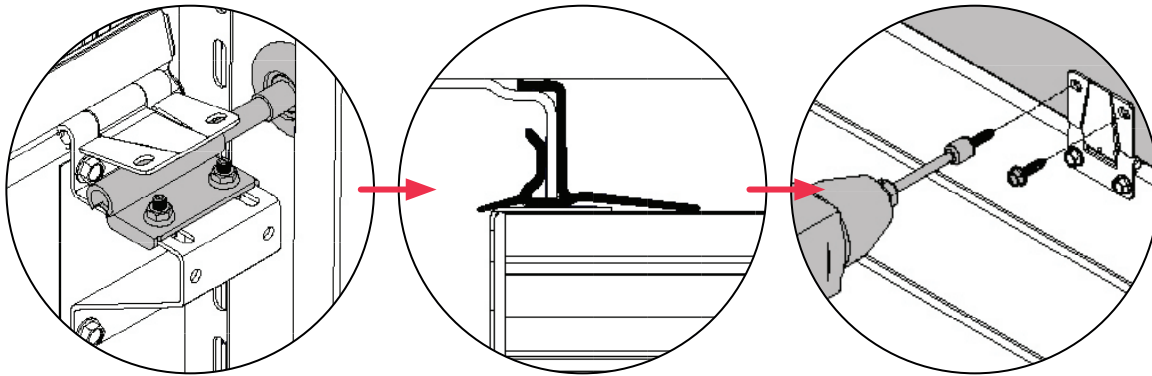
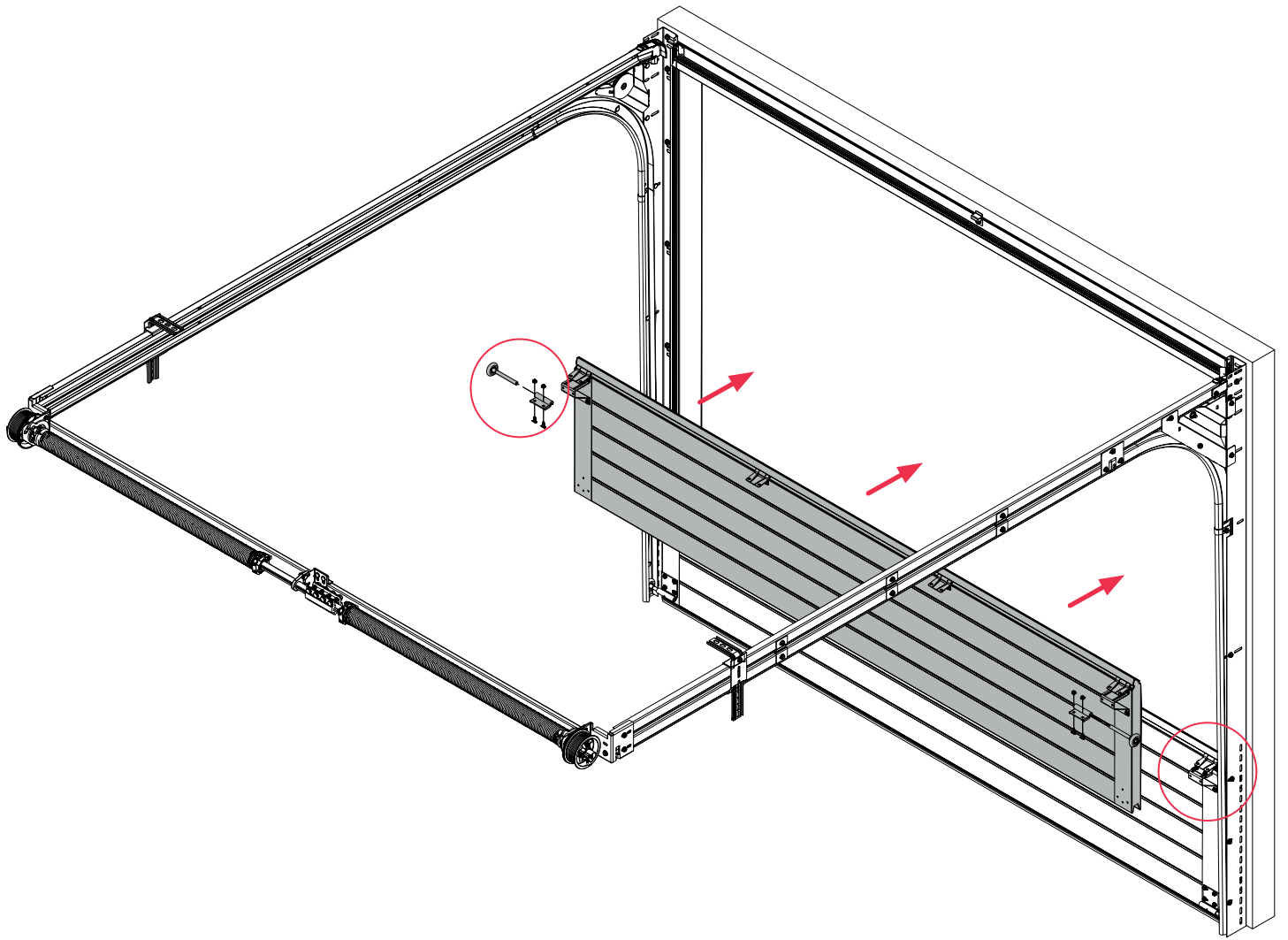

3814 (16mm)
3812 (25mm)

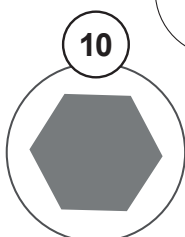
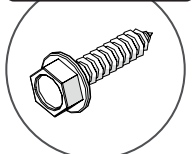

10

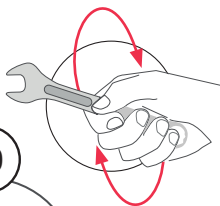

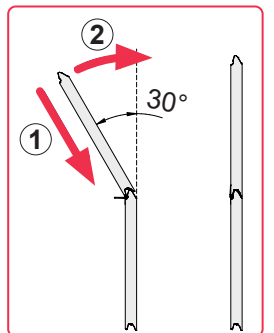
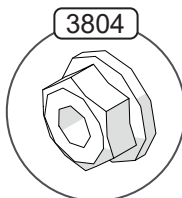
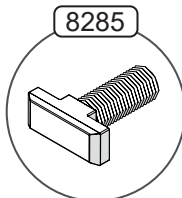
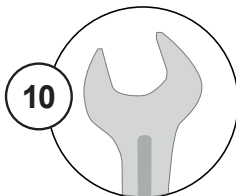
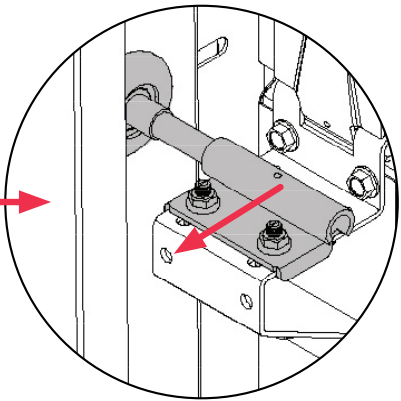
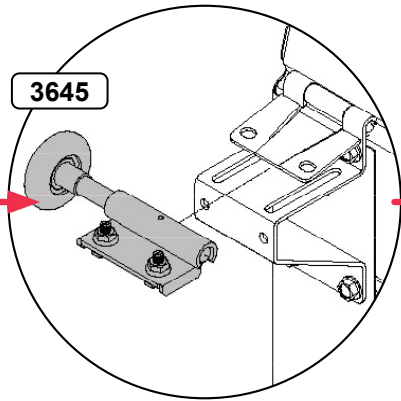
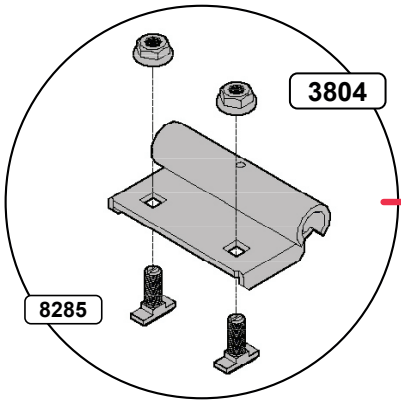
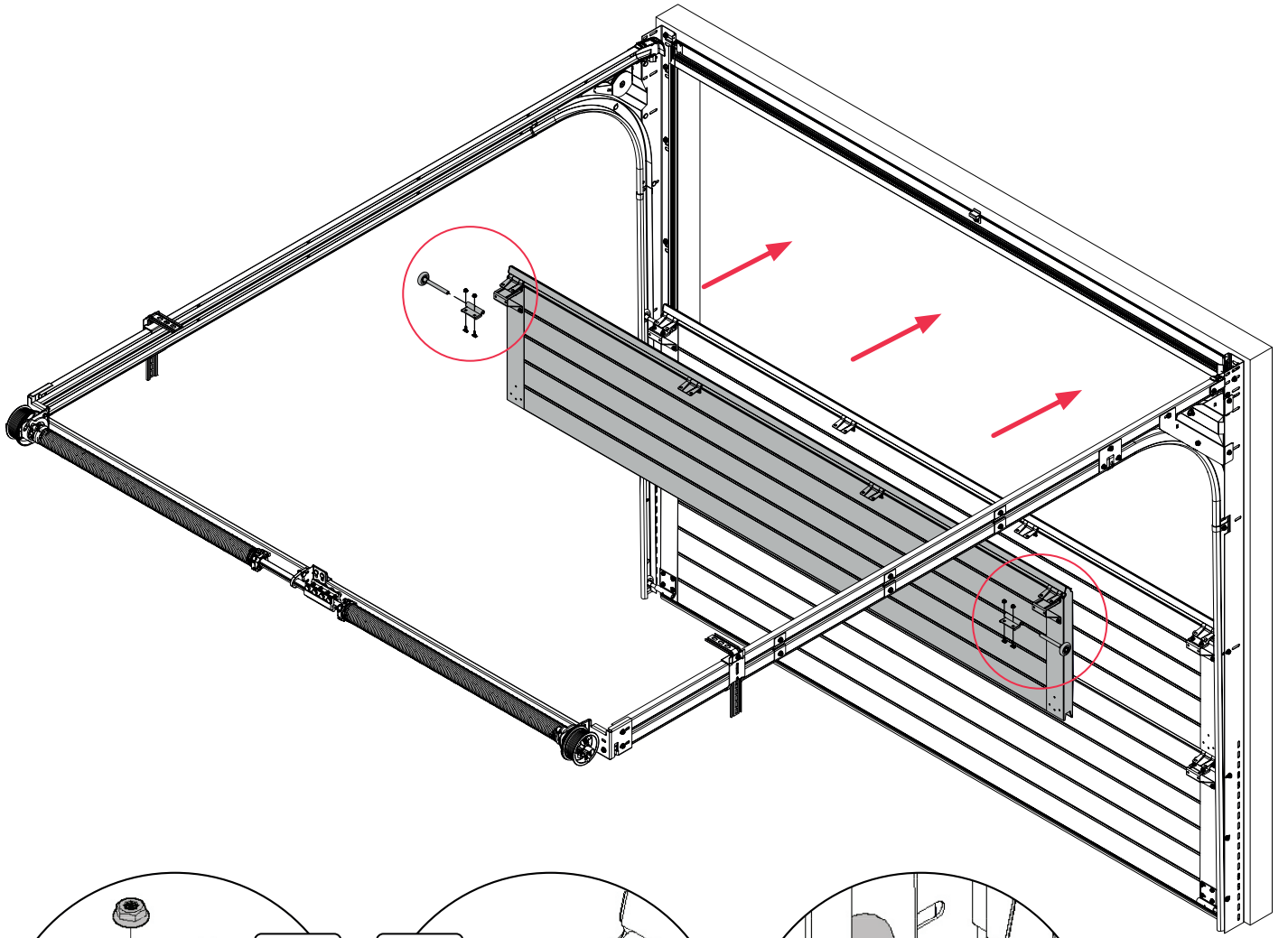

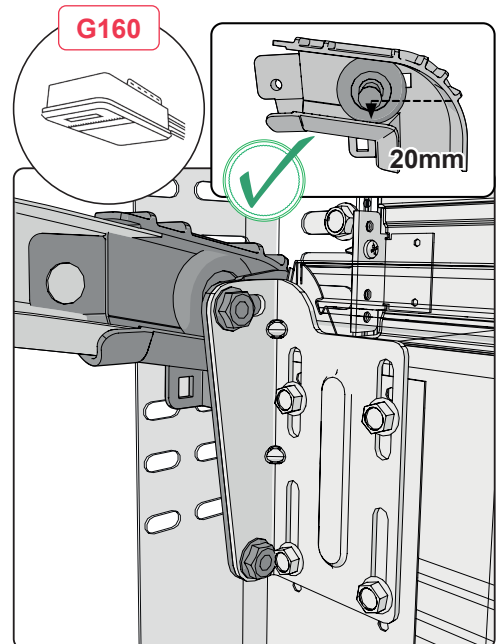
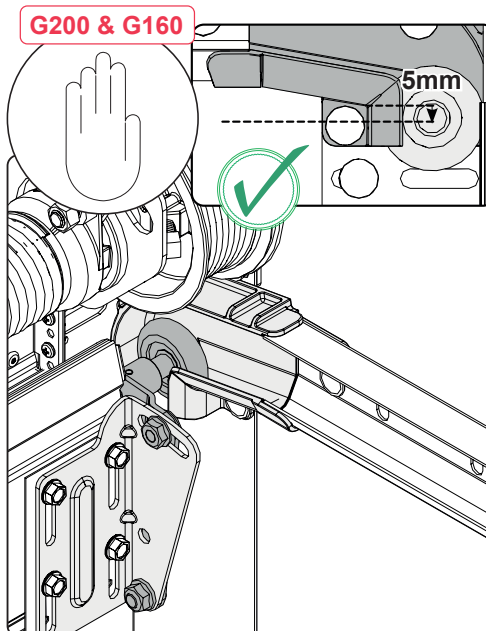
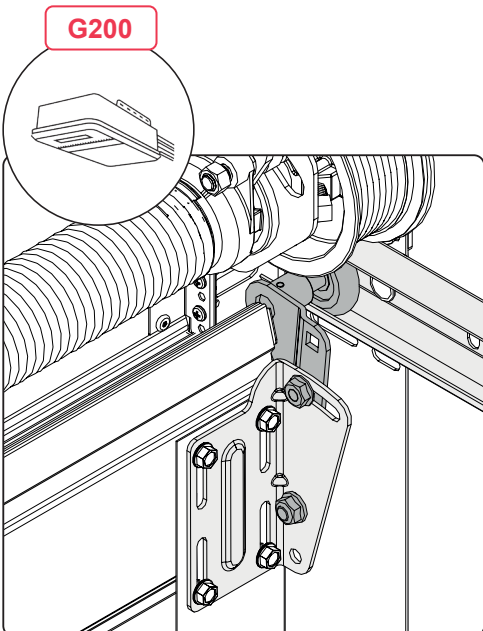
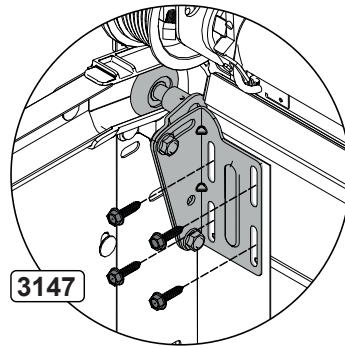
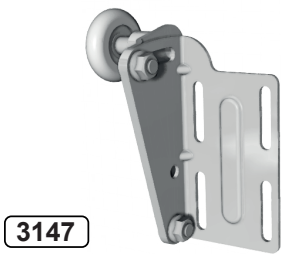
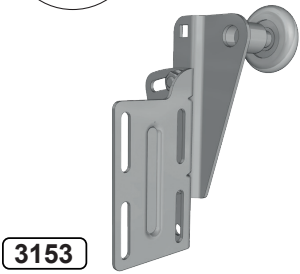
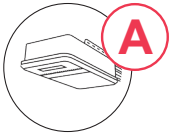
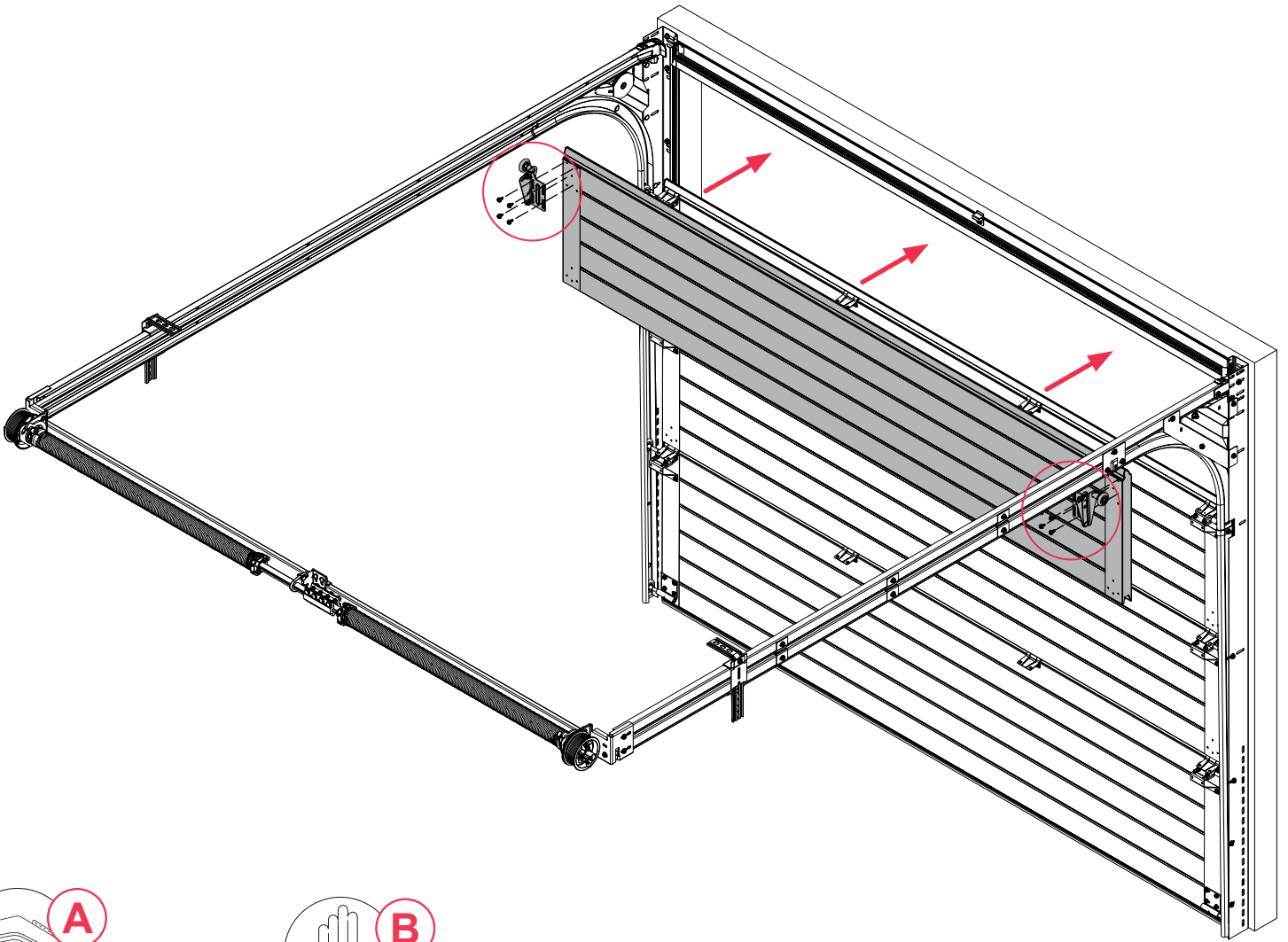

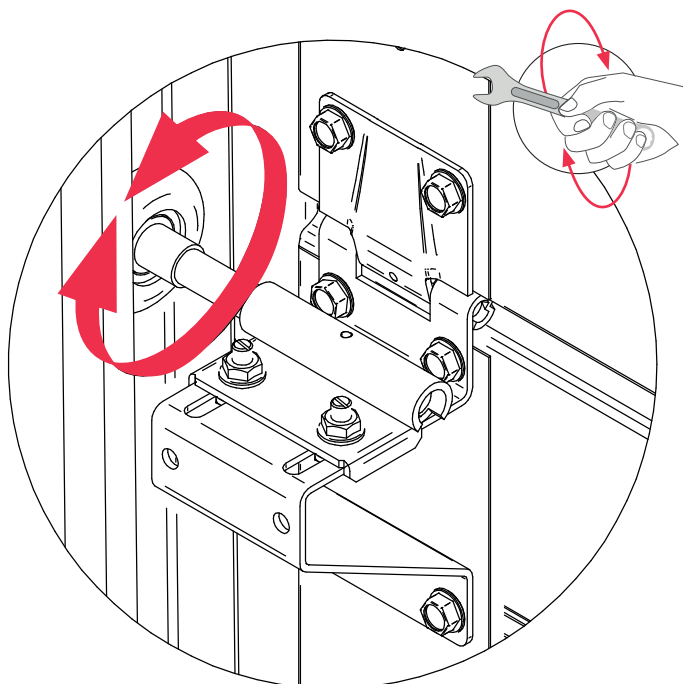
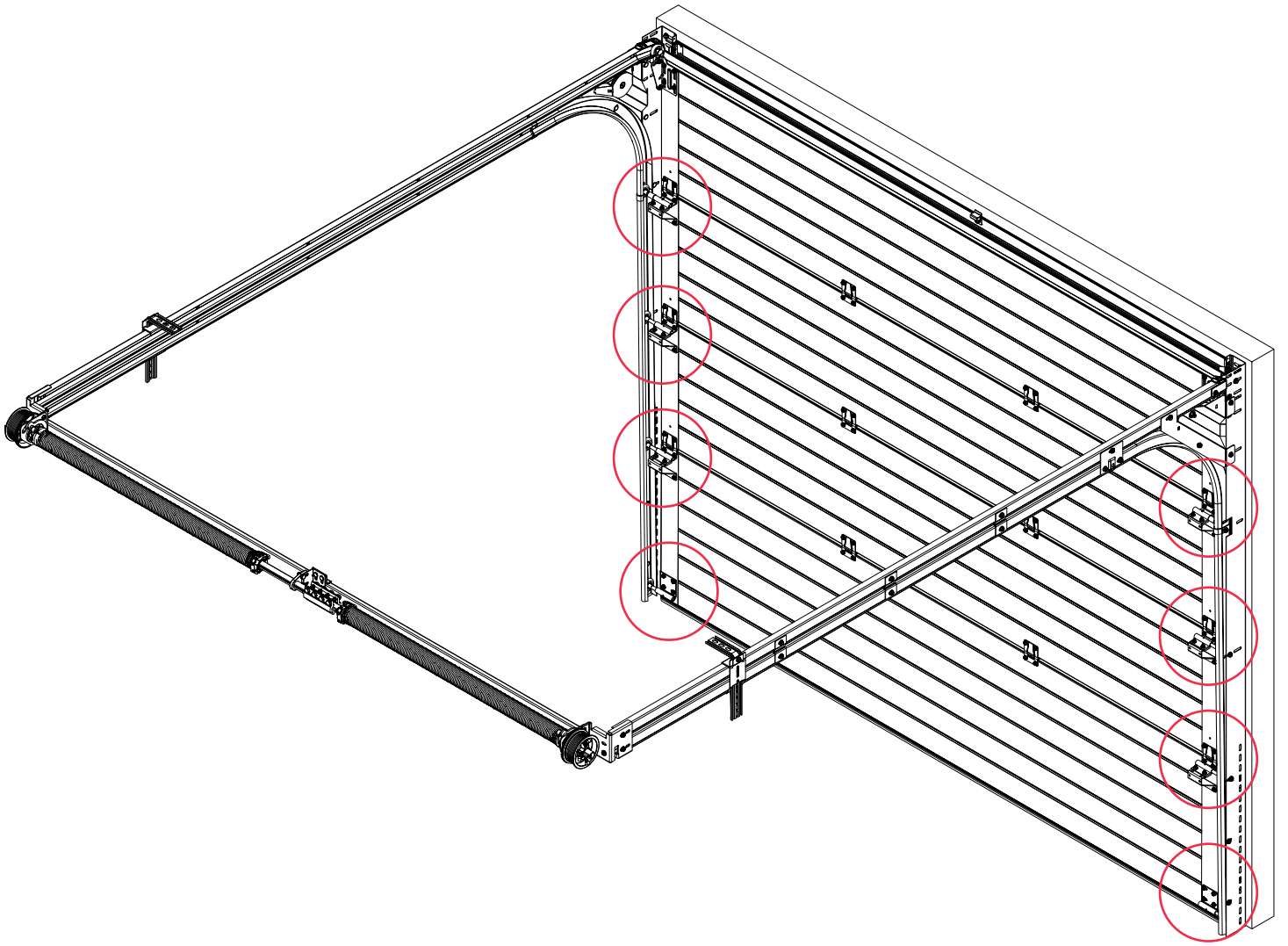

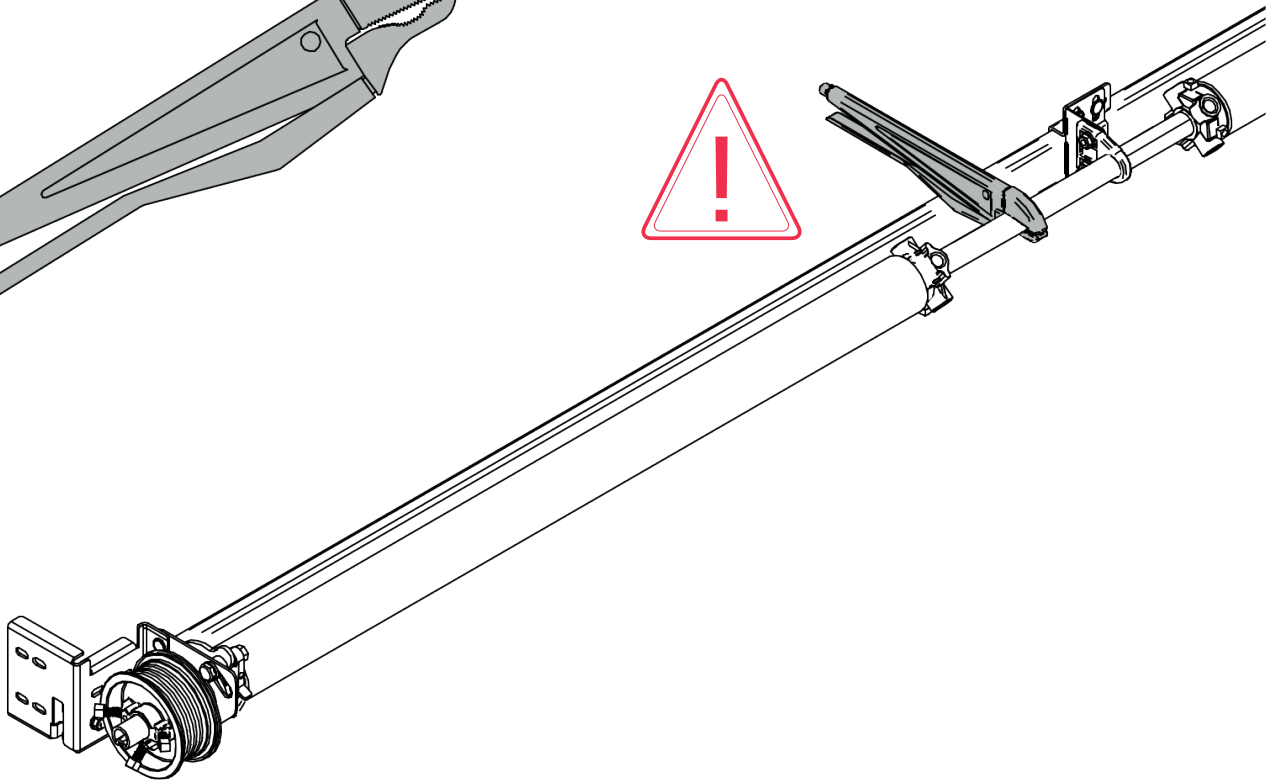
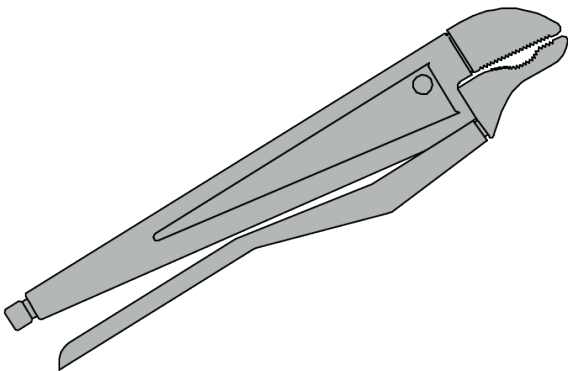
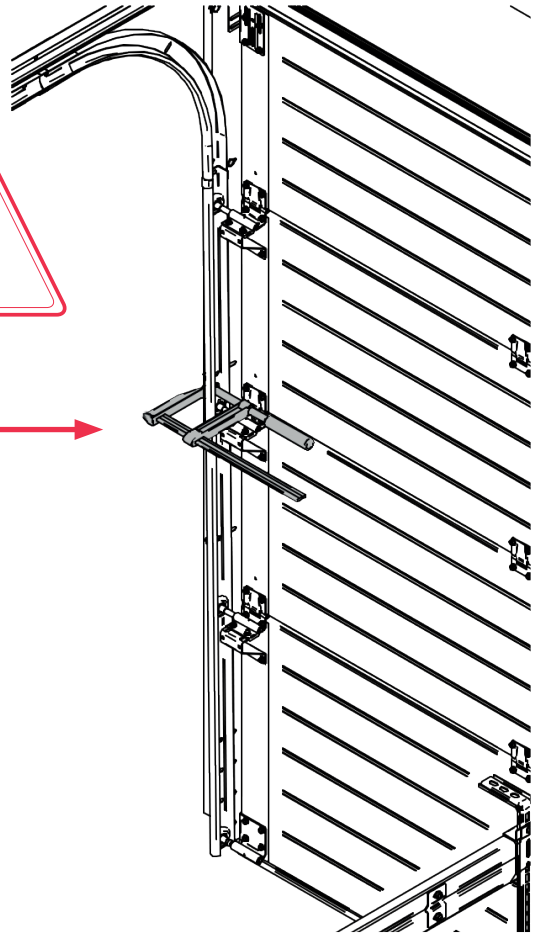
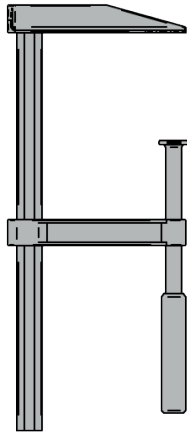

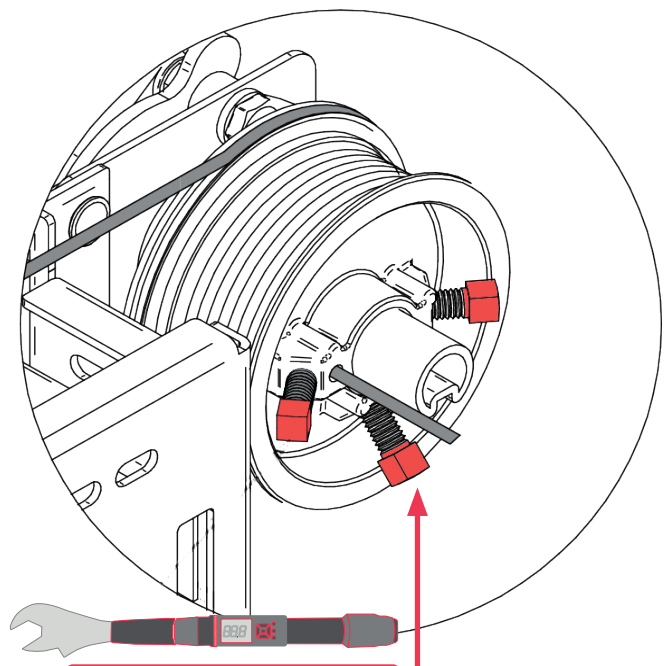
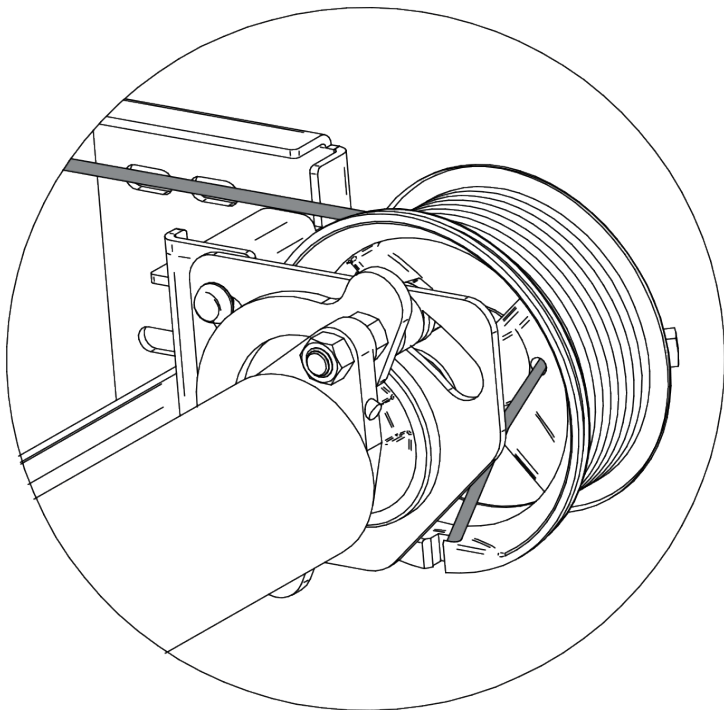
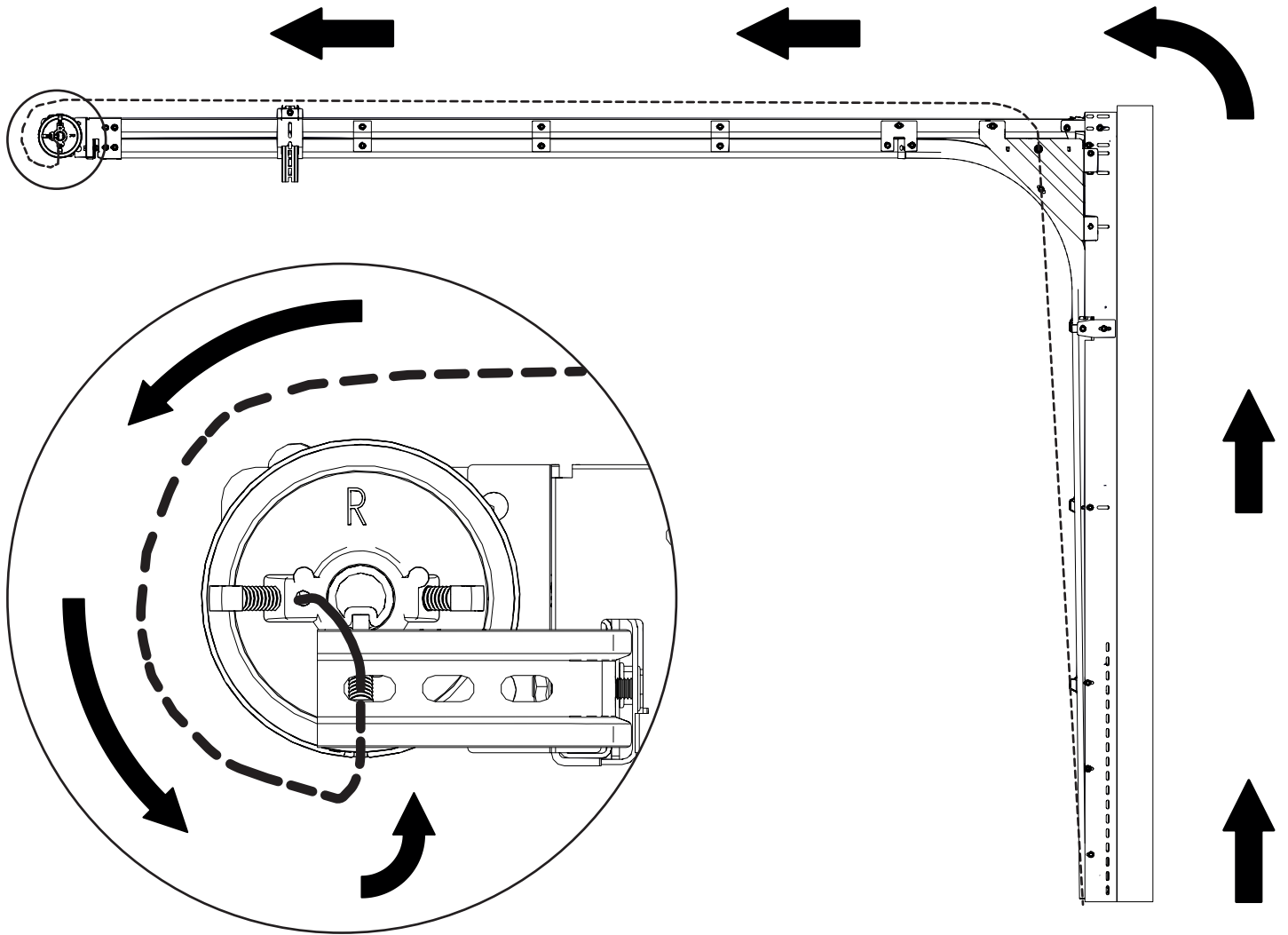

Ø 51 = 27Nm Max.
Ø 67 = 34Nm Max.

EN: Tension short and long
 NL: Spanijzers kort en lang
 FR: Barre de tension court et long
 ES: Tensores regulables corto y largo
 DE: Feder Spanndorn kurz und lang

EN: Spring NL: veer FR: ressort ES: muelle DE: Feder < 67 mm

Customer Ref.:
 Our reference:

Download the manual on www.doormanuals.com or scan the QR code



Turns x 360°



DANGER!

Qty	Doortype	DLW	DLH	Sections	Fields	Assembly	Weight	Turns
<input type="text"/>	<input type="text"/>	<input type="text"/>	x <input type="text"/>	<input type="text"/>	<input type="text"/>	<input type="text"/>	<input type="text"/>	<input type="text"/>

Qty	Unit	Art. num.	Article description	Length
1	piece	8800	Torsion spring right powder coat 4.75x51x412	
1	piece	8850	Torsion spring left powder coat 4.5x51x380	

1

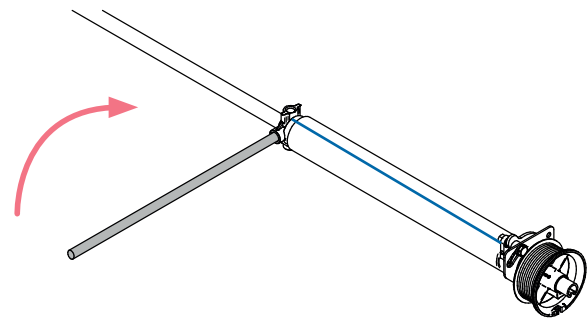
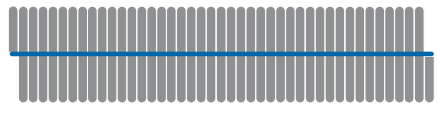

2

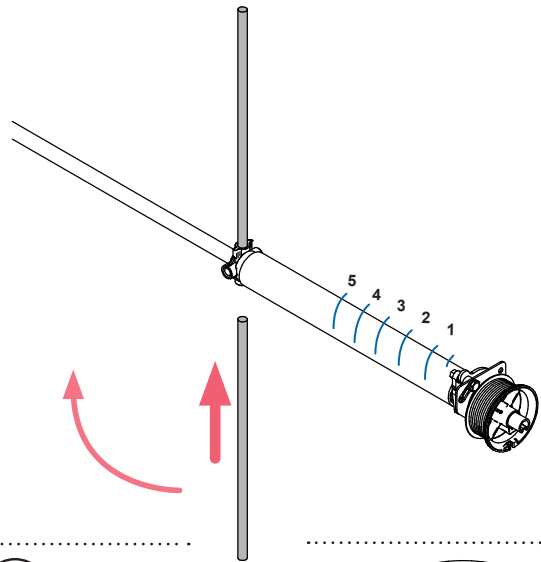
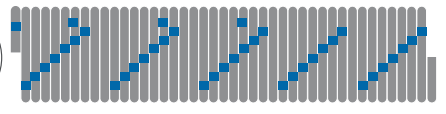
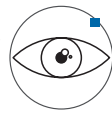

3

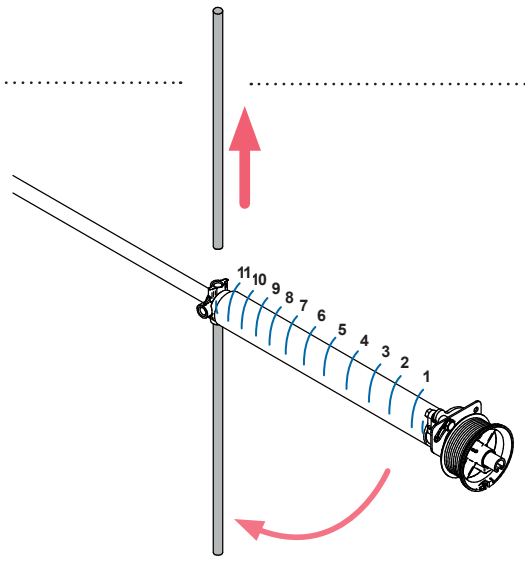

4

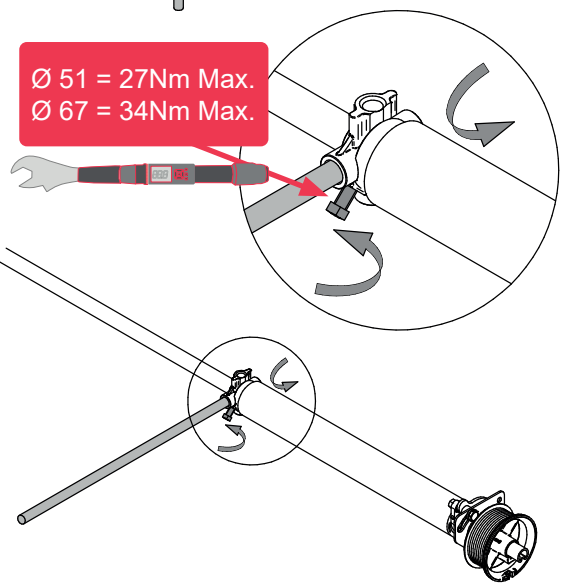

NL: Correcte wijze vastzetten van spankop.
EN: Correct fastening of winding plug.
FR: Fixation correcte du mandrin de tension.
ES: Richtige montage Feder spannkopf.
DE: Korrekte Befestigung des Spannkopfes.

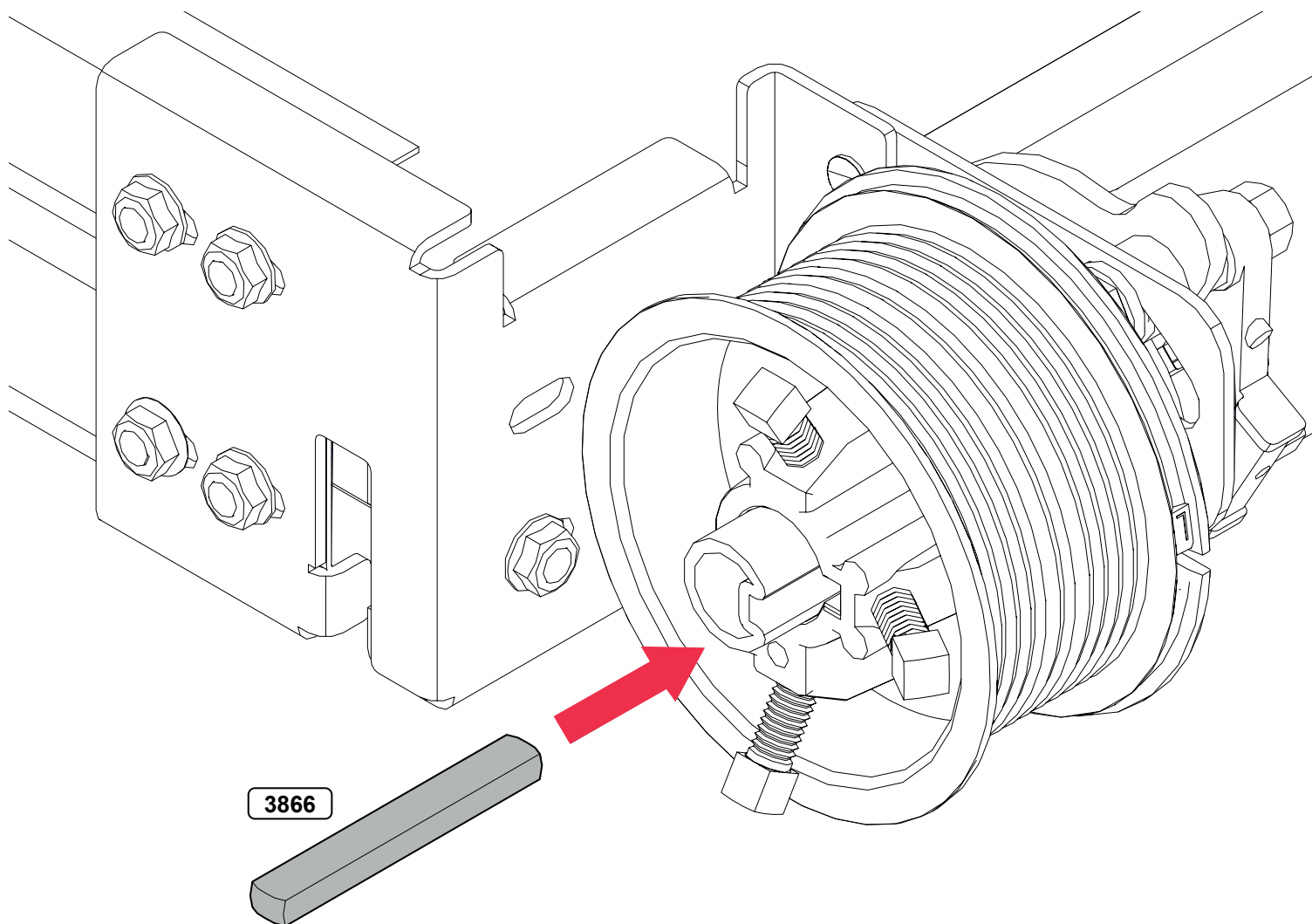
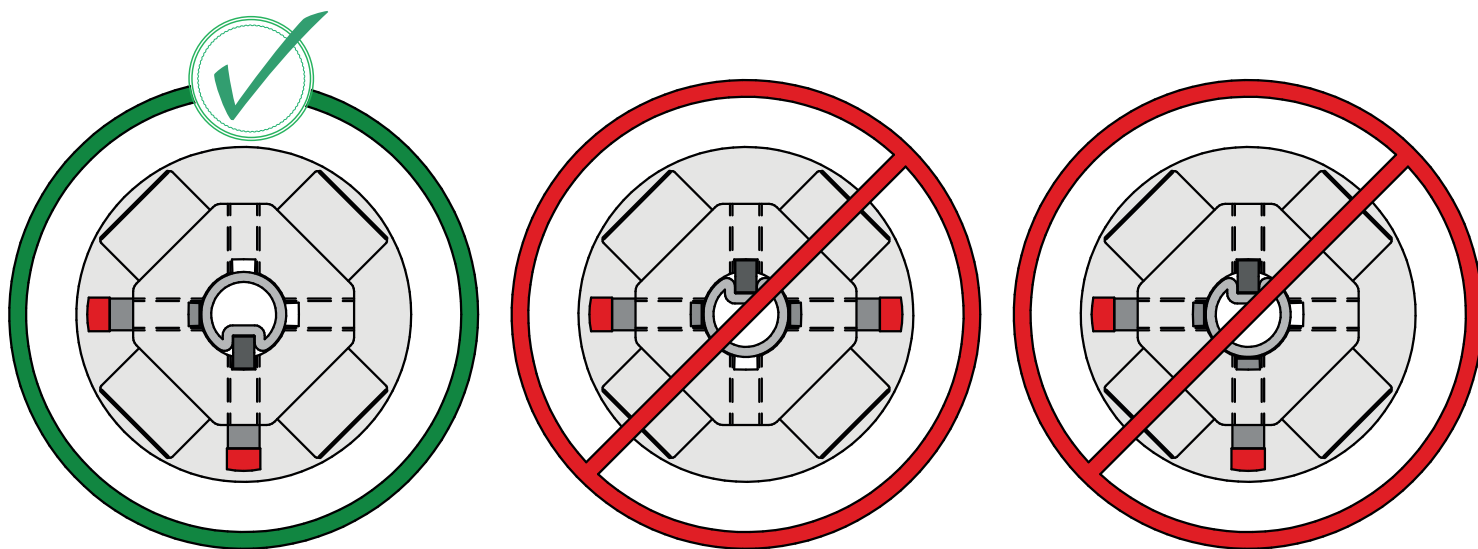

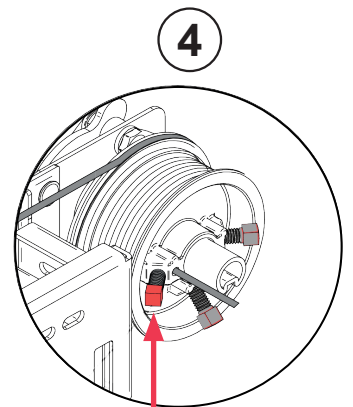
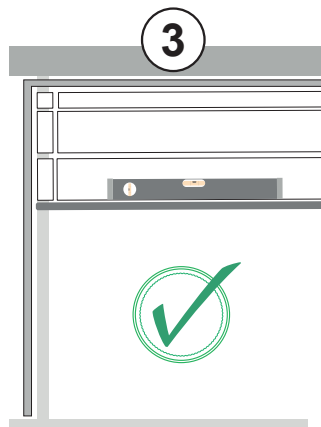
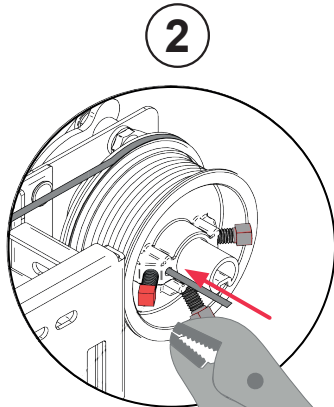
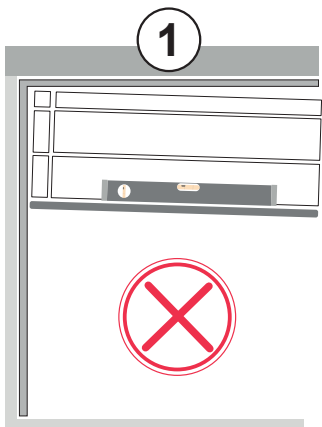
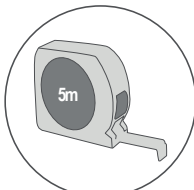
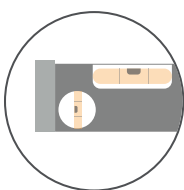
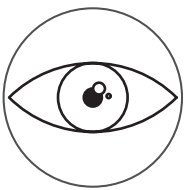
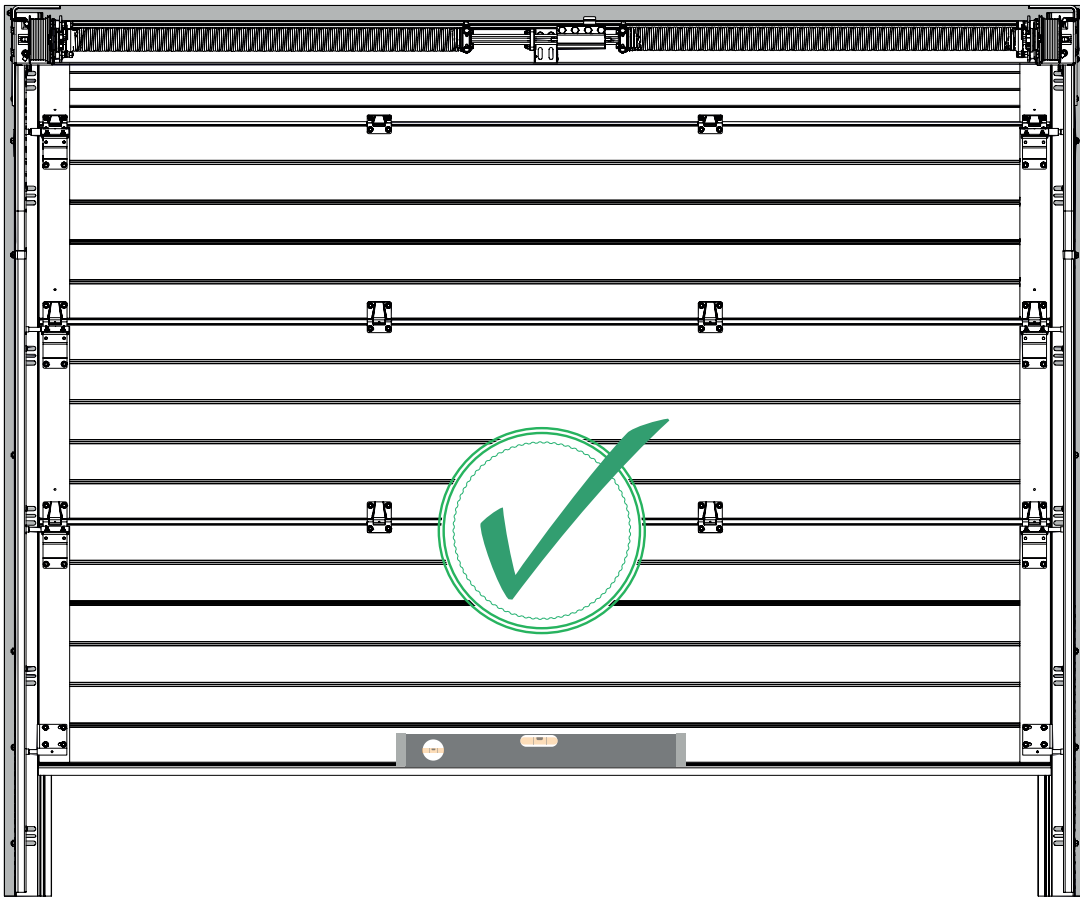

Ø 51 = 27Nm Max.
Ø 67 = 34Nm Max.

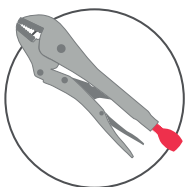
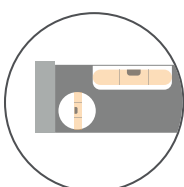
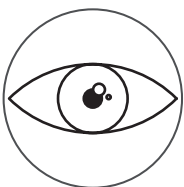

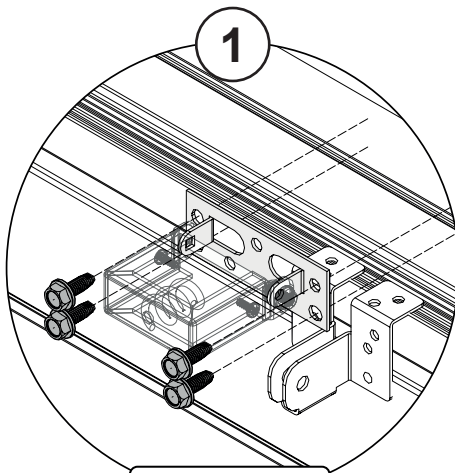
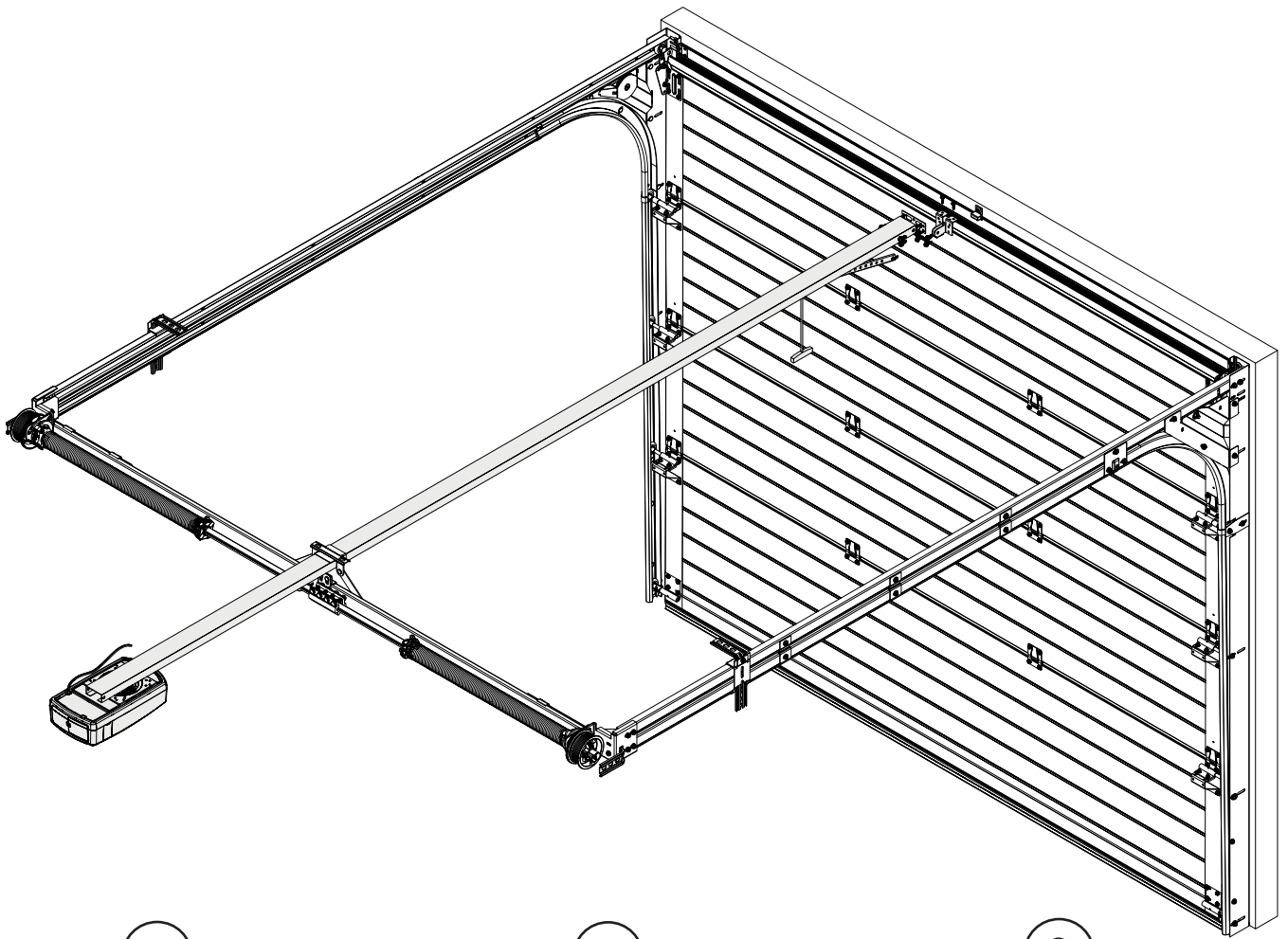

1
C9958/ C9959

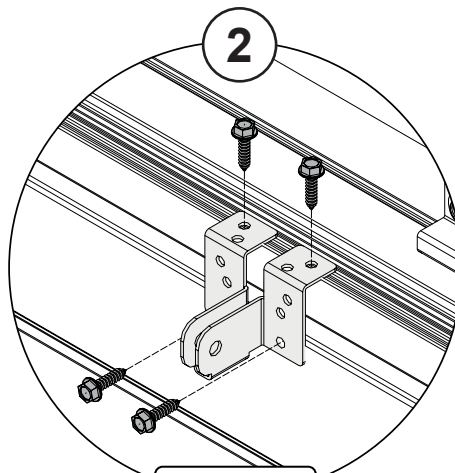

2
3814/ 3812

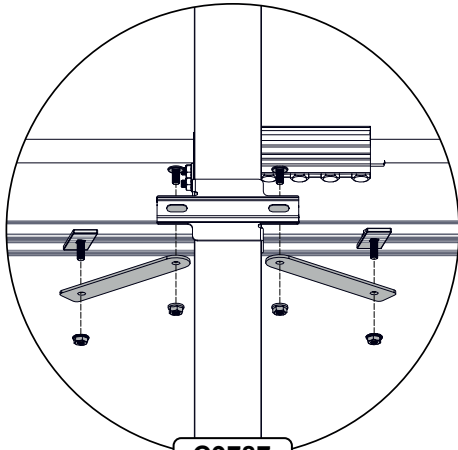
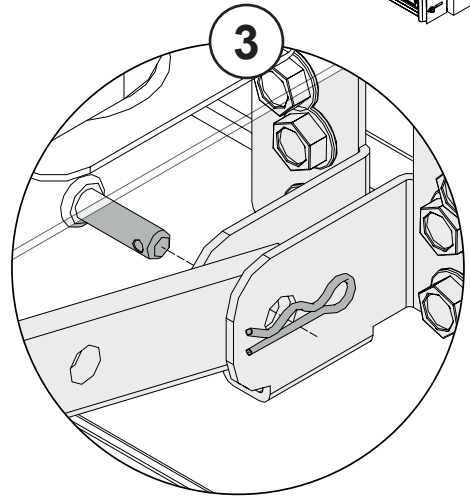

C9787

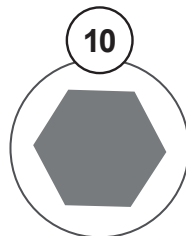

10

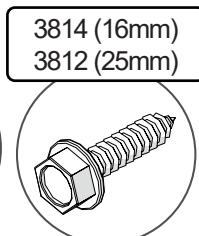

3814 (16mm)
3812 (25mm)

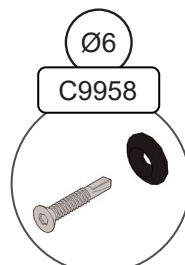

Ø6
C9958

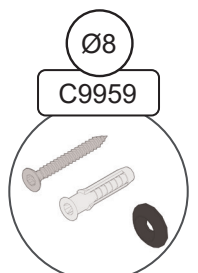

Ø8
C9959

OPTION

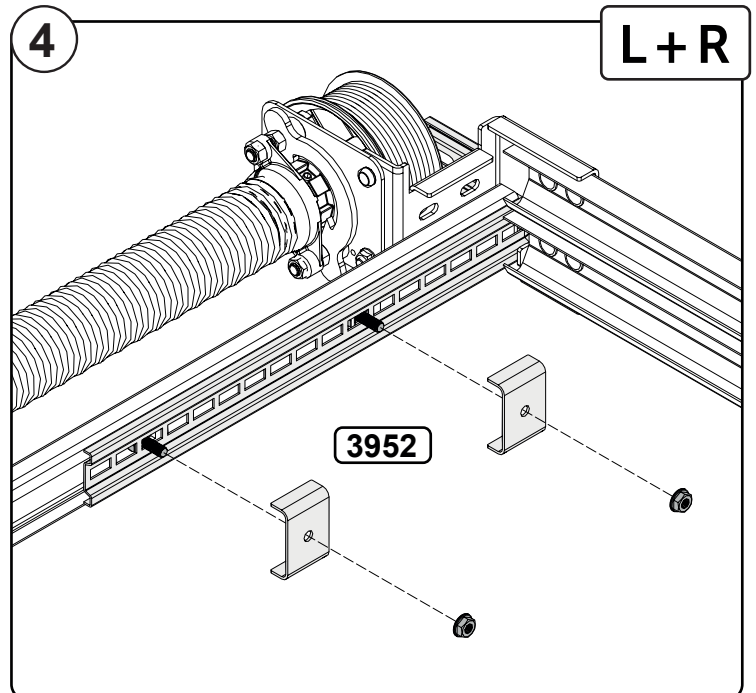
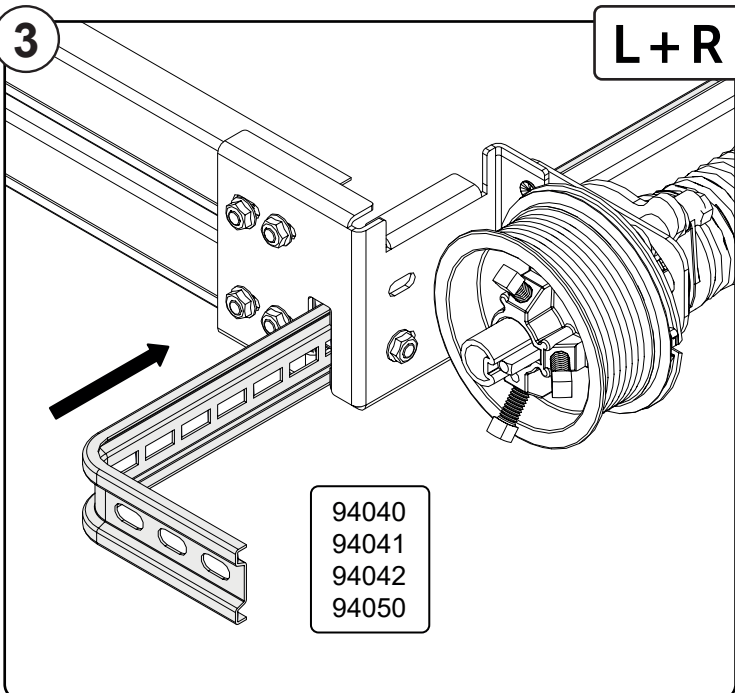
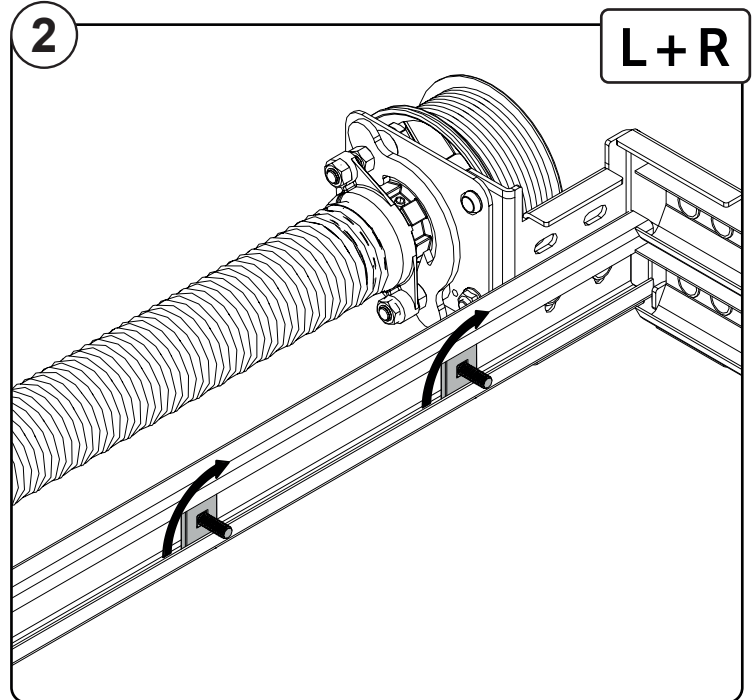
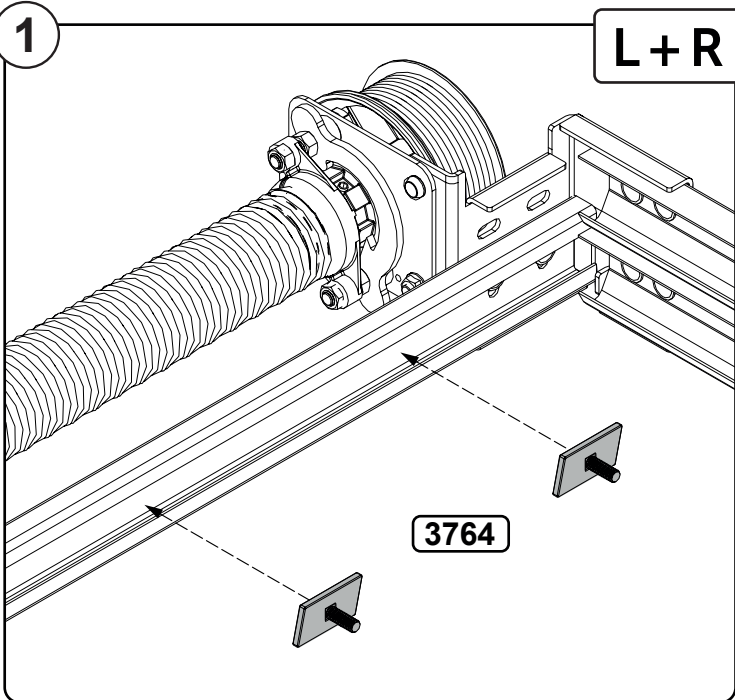
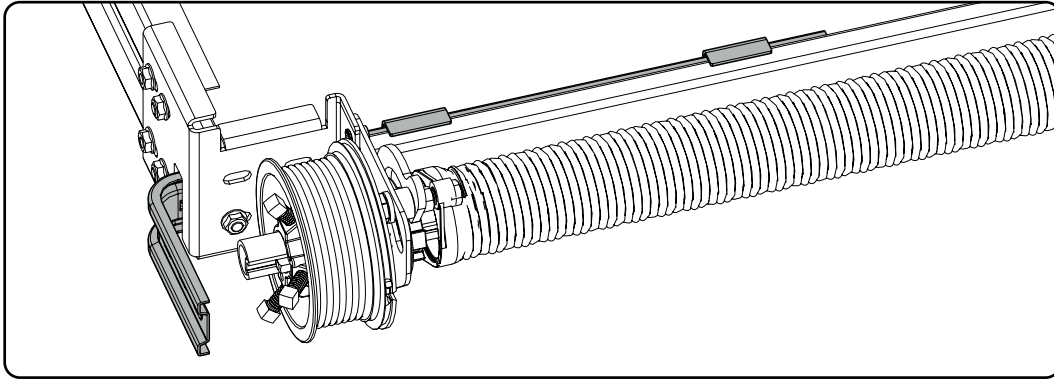

OPTION

